

For MC9700, MC9500, MC350E & MC300E

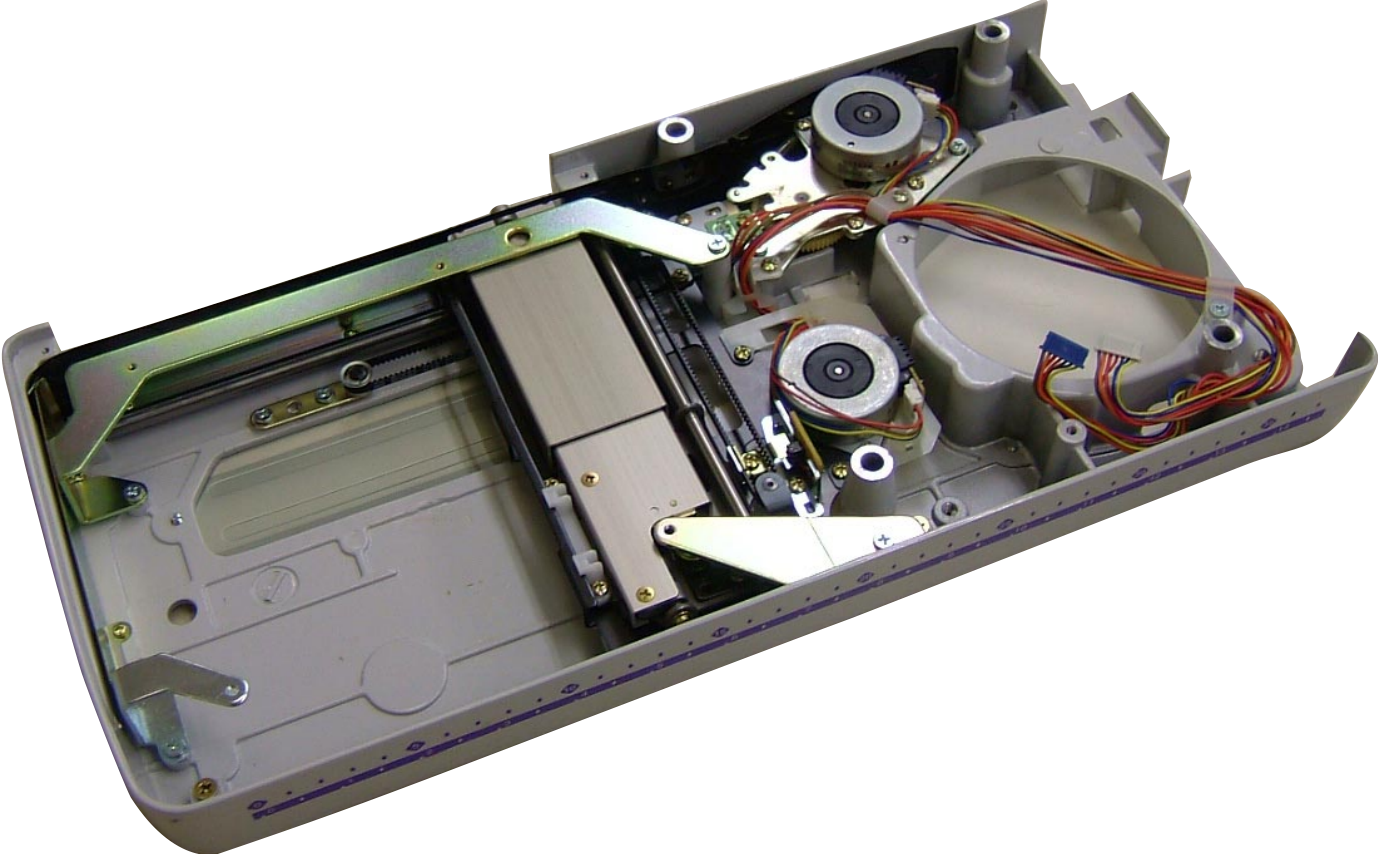
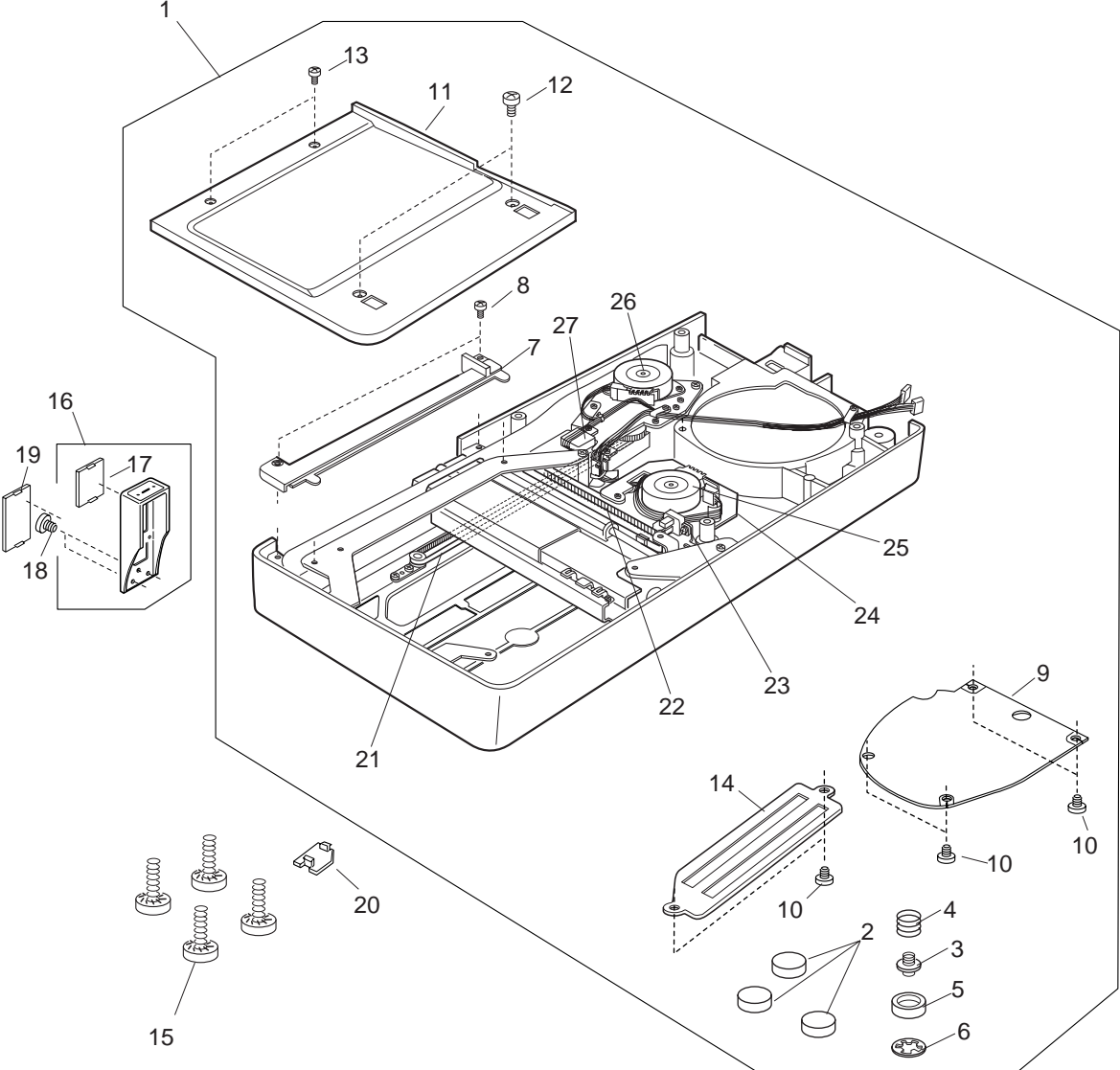

For MC9700, MC9500, MC350E & MC300E

Ref.	Part No.	Description
1	852617001	Base unit for MC9700, MC9500, MC300E
	852617104	Base unit for MC350E
2	830150003	Rubber foot
3	820350004	Adjusting screw
4	820351005	Adjusting screw spring
5	605074008	Rubber foot
6	813123004	CS ring
7	850146008	Sheet cover set plate
8	000066727	Setscrew 3 x 8
9	850151017	Base lid
10	810220106	Setscrew
11	851053103	Base cover
12	000101426	Setscrew 4 x 6
13	000101127	Setscrew 3 x 4
14	832146002	Base lid (1)
15	000127107	Setscrew 6 x 35
16	850627008	Carriage plate unit
17	850169007	Cover lid (2)
18	000078319	Setscrew 3 x 6
19	850156001	Cover lid
20	851071004	Base lid (3)
21	850106006	Syncronized belt 380
22	850116009	Syncronized belt 290
23	843503407	Printed circuit board E2 (Y-sensor)
24	852619003	Y-carriage unit
25	850511008	Stepping motor 42
26	852618002	X-motor unit
27	852511004	Printed circuit board G2 (X-sensor)
28	850141003	Dust cover