

MC 9500 & MC 300E — Base —

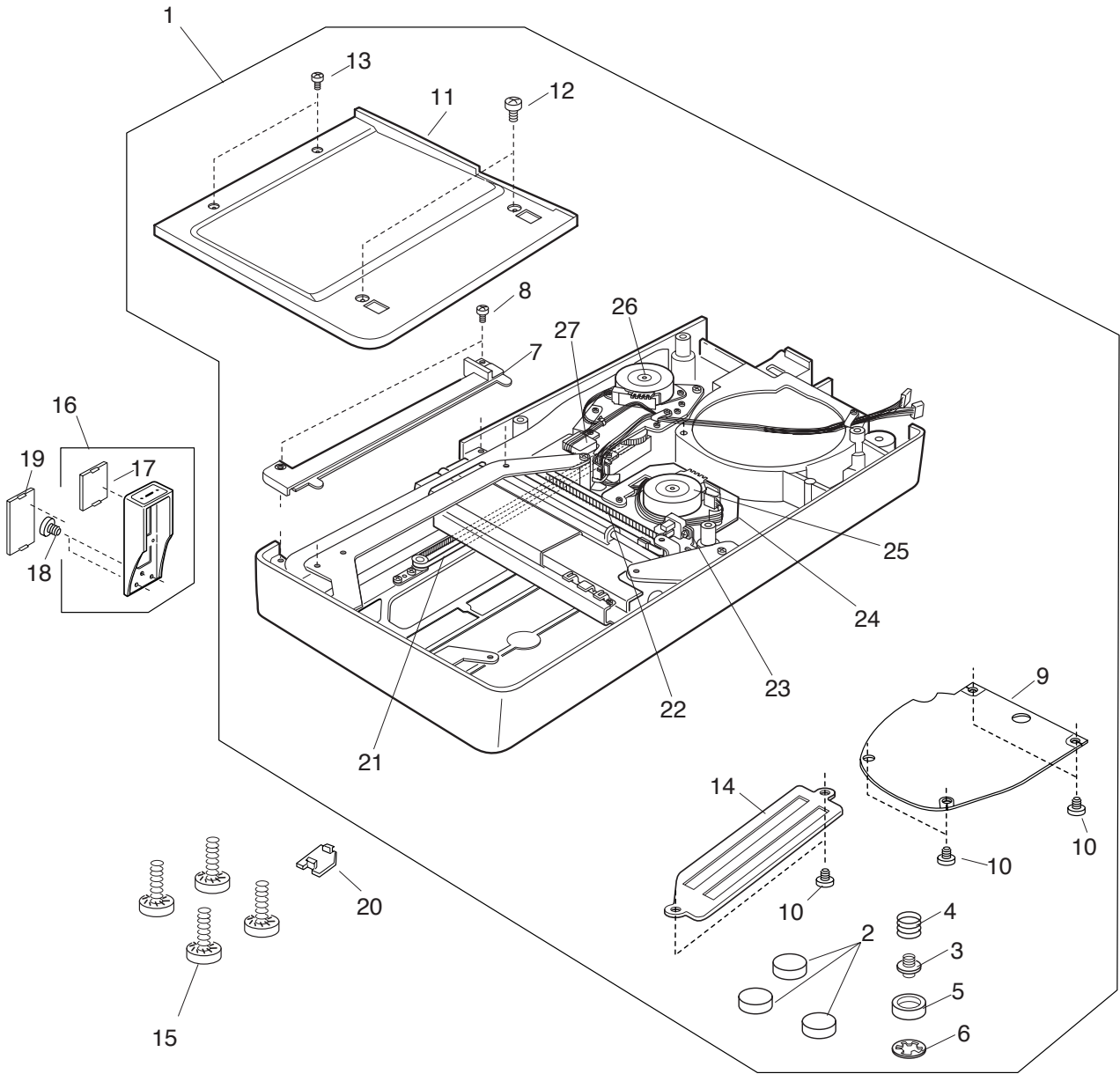

NO.	Parts Number	Name
1	852617001	Base unit
2	830150003	Rubber foot
3	820350004	Adjusting screw
4	820351005	Adjusting screw spring
5	605074008	Rubber foot
6	813123004	CSring
7	850146008	Sheet cover
8	000066727	Setscrew 3 x 8
9	850151017	Base lid
10	810220106	Setscrew
11	851053103	Base cover
12	000101426	Setscrew 4 x 6
13	000101127	Setscrew 3 x 4
14	832146002	Base lid (1)
15	000127107	Setscrew 6 x 35
16	850627008	Carriage plate unit
17	850169007	Cover lid (2)
18	000078319	Setscrew 3 x 6
19	850156001	Cover lid
20	851071004	Base lid (3)
21	850106006	Syncro belt 380
22	850116009	Syncro belt 290
23	843503407	Printed circuit board E2 (Y-sensor)
24	852619003	Y-carriage unit
25	850511008	Stepping motor 42
26	852618002	X-motor unit
27	852511004	Printed circuit board G2 (X-sensor)