

Brother

KH260

CATALOGO PARTI DI RICAMBIO

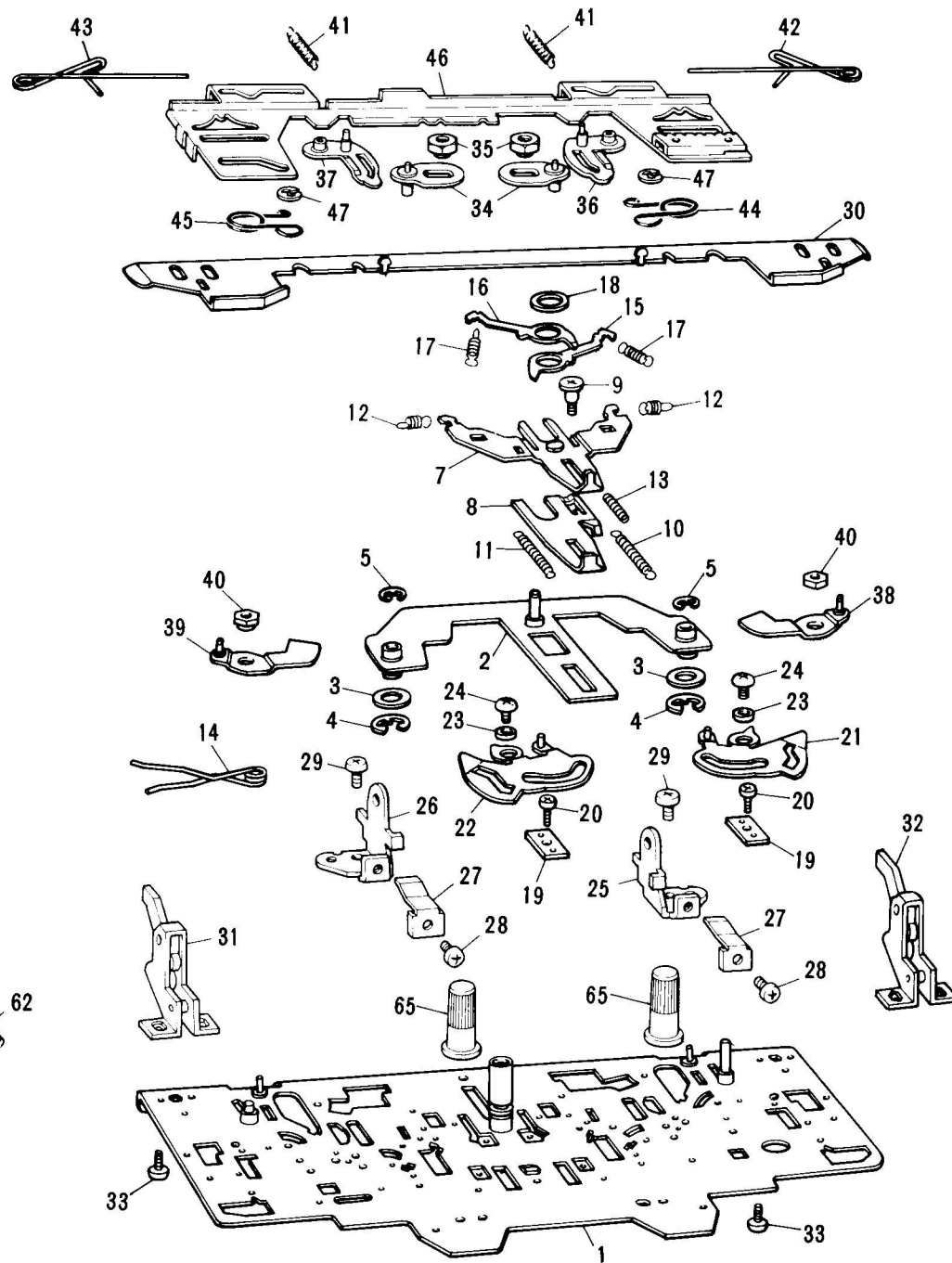
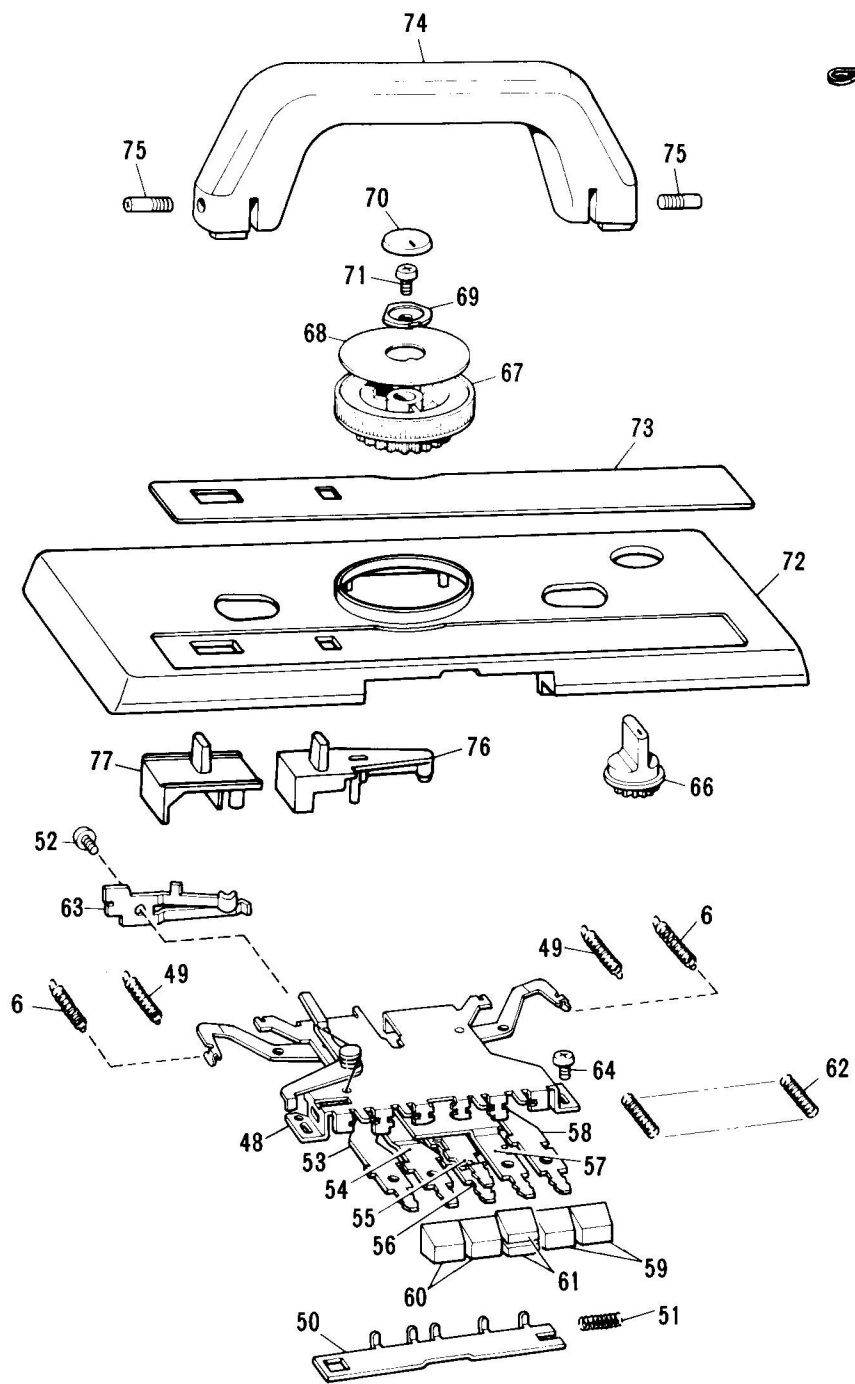

PARTS FOR CARRIAGE **Fig: A I**

PARTS FOR CARRIAGE UPPER PART

Ref. No.	Parts No.	Description	Revised	Q'ty	Ref. No.	Parts No.	Description	Revised	Q'ty
A11-77 & A1178-201	413592001	K carriage complete set KH-260		1					
A1- 1	413252001	Carriage plate		1	*45	409544001	Connecting plate spring, left		1
2	413257001	Stitch cam guide plate		1	46	413364001	Upper slide plate assembly		1
*3	405483001	Washer		2	*47	048040346	Snap ring		2
*4	048070346	Snap ring		2	48-63	413372002	Cam button unit		1
*5	048030346	Snap ring		2	63	413380001	Stitch dial notch spring		1
*6	407432001	Raising cam change spring		2	*64	060670406	+ - screw 3.57 X 4		2
7	413305001	Change plate A		1	65	409596003	Thumb nut		2
8	413307000	Change plate B		1	*66	409597007	Change knob		1
9	413308001	Change plate guide collar		1	67-68	413580001	Stitch dial assembly		1
10	413309001	Change plate A spring		1	67	413382001	Stitch dial		1
*11	407318001	Change plate spring		1	68	413581001	Stitch dial indicator plate		1
12	413559001	MC cam spring		2	*69	406283001	Stitch dial presser		1
13	413452001	Change plate B spring		1	70	409601004	Stitch dial cap		1
*14	407333001	H.C.L. spring		1	*71	060660606	Screw		1
15	413314001	Tuck cam operating plate, right		1	72-73	413591101	K carriage cover assembly KH-260		1
16	413315001	Tuck cam operating plate, left		1	72	413582001	K carriage cover		1
*17	407342001	Tuck cam spring		2	73	413583101	K carriage cover decoration plate KH-260		1
18	413316001	Presser ring		1	74	409605007	K carriage handle		1
19	413280001	Push up cam slide plate		2	*75	409608001	Screw		2
20	413281001	Screw		2	76	413437001	Plain lever knob		1
21	413367001	Push-up change plate, right		1	77	413387001	H.C.L. knob		1
22	413370001	Push-up change plate, left		1					
23	413544001	Collar		2					
24	413554001	Screw		2					
25	413599001	Handle setting base, right		1					
26	413600001	Handle setting base, left		1					
*27	409522001	Handle lock spring		2					
*28	060670406	+ - screw 3.57 X 4		2					
*29	060680506	+ - screw 4.37 X 5		2					
30	413354001	Rear plate		1					
*31	409967001	Knit-leader tripper assembly		1					
32	413355001	Row counter tripper assembly		1					
*33	060660406	+ - screw 3.18 X 4		4					
*34	409567001	S.M. cam lever		2					
*35	409571001	Nut		2					
*36	409572001	S.M. cam change crank, right		1					
*37	409576001	S.M. cam change crank, left		1					
38	413357001	Cam change plate, right		1					
39	413359001	Cam change plate, left		1					
40	413361001	Nut		2					
*41	409585001	Needle selection change lever spring		2					
42	413362001	Valve cam E spring, right		1					
43	413363001	Valve cam E spring, left		1					
*44	409543001	Connecting plate spring, right		1					

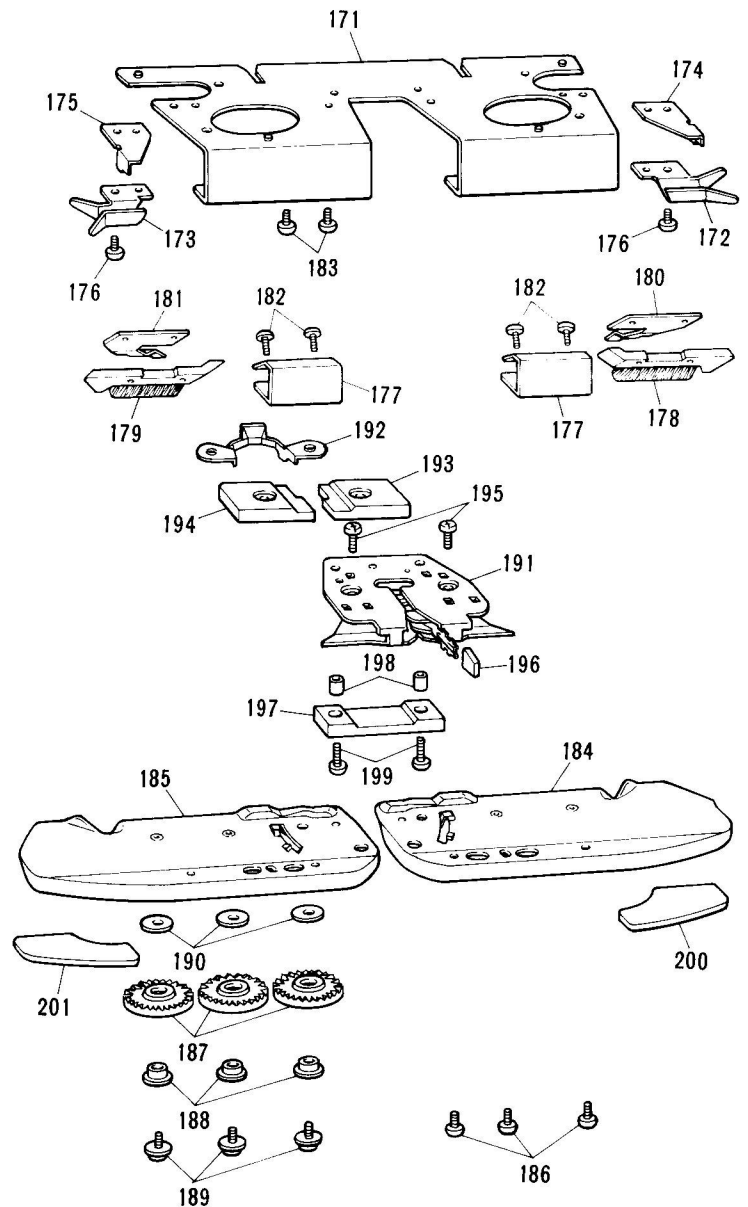
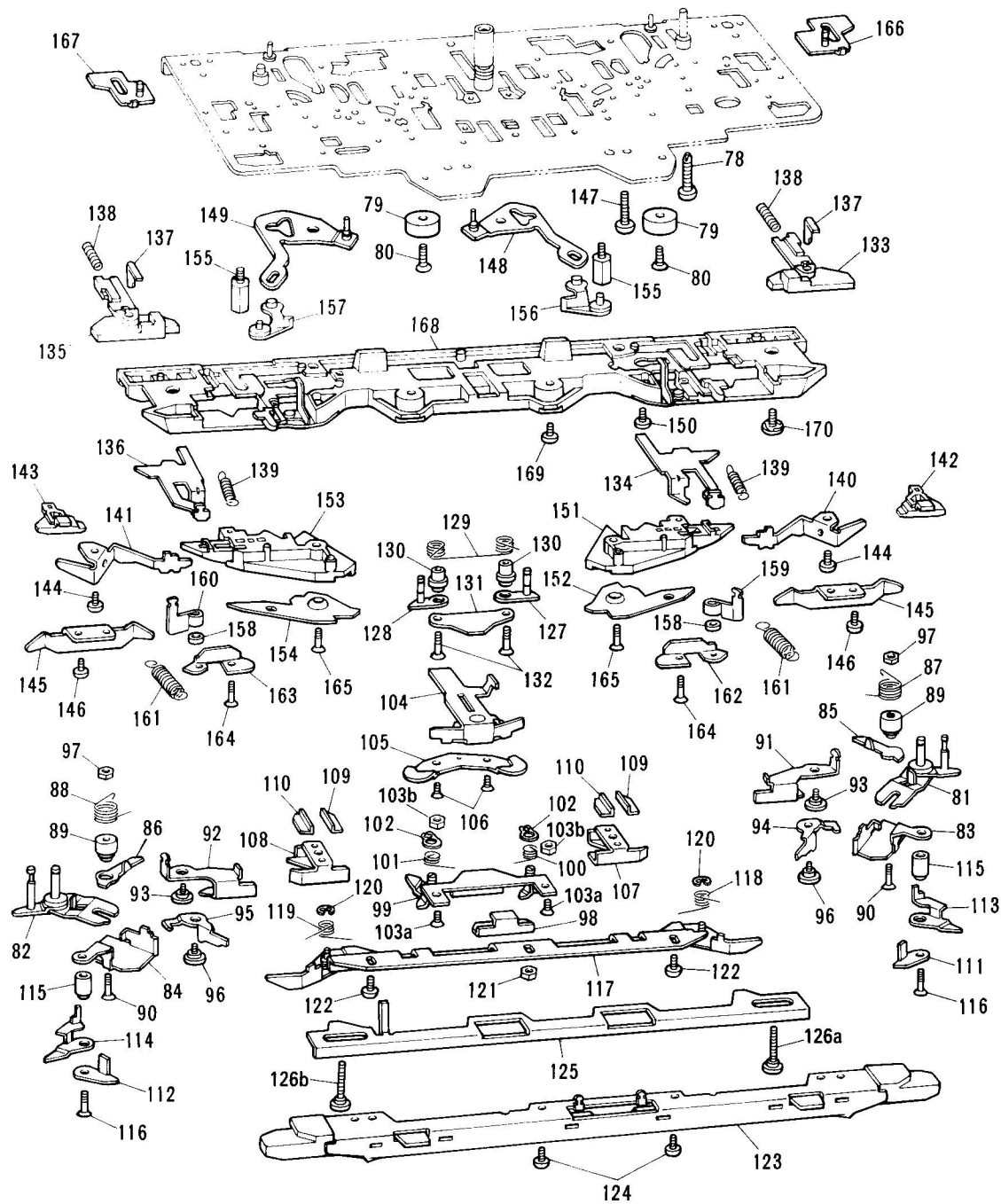

PARTS FOR CARRIAGE **Fig : A II**

PARTS FOR CARRIAGE LOWER PART

Ref. No.	Parts No.	Description	Revised	Q'ty	Ref. No.	Parts No.	Description	Revised	Q'ty
*All-78	037351615	Tapping screw		2	*121	408524001	Nut		1
*79	407285000	Carriage magnet 16		2	*122	408305002	Screw		2
*80	408773006	Flat head screw 3.18 X 9		2	123	413310001	Front foot		1
81	413259001	Stitch cam assembly, right		1	*124	408305002	Screw		2
82	413264001	Stitch cam assembly, left		1	*125	407328000	Front slide plate		1
83	413268001	Sub stitch cam, right		1	*126a	408504001	Stud screw 3.18		1
84	413269001	Sub stitch cam, left		1	126b	408505001	Stud screw 3.18		1
85	413270001	Valve cam D, right		1	*127	407579001	Tuck cam, right		1
86	413271001	Valve cam D, left		1	*128	407586001	Tuck cam, left		1
87	413272001	Valve cam D spring, right		1	129	413312001	Tuck cam spring		1
88	413273001	Valve cam D spring, left		1	*130	407339001	Shaft for tuck cam		2
89	413274001	Sub stitch cam shaft		2	131	413313001	Tuck cam plate		1
90	413557001	Screw		2	*132	407299001	Screw		2
91	413275001	MC cam, right		1	133	413317001	Selection cam for right end needle		1
92	413276001	MC cam, left		1	134	413318001	Selection guide for right end needle		1
93	413626001	Screw		2	135	413319001	Selection cam for left end needle		1
94	413282001	Valve cam A, right		1	136	413320001	Selection guide for left end needle		1
95	413283001	Valve cam A, left		1	137	413321001	End needle selection switch cam		2
96	413277001	Stud screw 3.18		2	138	414244001	End needle selection cam spring		2
97	408524001	Nut 3.18		2	139	413556001	End needle selection spring		2
98	413298001	Slide cam		1	140	413322001	Separation cam, right		1
99-102	413550001	Slide guide cam assembly		1	141	413323001	Separation cam, left		1
99	413290001	Slide guide cam		1	142	413447000	Buffer right for selected needle		1
100	413295001	Valve cam B spring, right		1	143	413448000	Buffer left for selected needle		1
101	413296001	Valve cam B spring, left		1	*144	060660406	+ - screw 3.18 X 4		2
102	048040142	Snap ring		2	*145	409519001	Guide cam F		2
103a	417175001	Flat head screw 3.18 X 4		2	*146	062660406	+ - screw 3.18 X 4		2
103b	021660306	Nut 3.18-40		2	*147	062681206	+ - screw 4.37 X 12		2
104	413449001	Thread-lace change plate		1	148	413324001	Needle selection change plate, right		1
105	413451001	Fastening plate for thread-lace change plate		1	149	413326001	Needle selection change plate, left		1
106	413285001	+ - screw 3.18 X 4		2	*150	409528001	Stud screw		2
107	413278001	Push up cam, right		1	151	413328001	Selection cam plate, right		1
108	413279001	Push up cam, left		1	152	413330001	Selection cam guide palte, right		1
109	413627001	Push-up cam holder plate, right		2	153	413331001	Selection cam plate, left		1
110	413628001	Push-up cam holder plate, left		2	154	413333001	Selection cam guide plate, left		1
111	413299001	MC guide cam, right		1	155	413334001	Shaft		2
112	413300001	MC guide cam, left		1	156	413335001	Needle selection change cam, right		1
113	413301001	MC guide change cam, right		1	157	413337001	Needle selection change cam, left		1
114	413302001	MC guide change cam, left		1	158	414205001	Needle selection change spacer		2
115	413304001	Shaft		2	159	414203001	Valve cam F, right		1
*116	407299001	Screw		2	160	414204001	Valve cam F, left		1
117-120	413548001	Guide cam A assembly		1	*161	413643001	Valve cam F, spring		2
117	413547001	Guide cam A		1	162	414201001	Guide cam G, right		1
*118	407325001	Holding cam spring, right		1	163	414202001	Guide cam G, left		1
*119	407326001	Holding cam spring, left		1	*164	407410001	Screw		2
120	048030346	Snap ring		2	165	061661206	Flat head screw 3.18 X 12		2

Ref. No.	Parts No.	Description	Revised	Q'ty	Ref. No.	Parts No.	Description	Revised	Q'ty
166	413342001	Connecting plate, right		1					
167	413344001	Connecting plate, left		1					
All-168	413346001	Rear foot		1					
*169	060660406	+ - screw 3.18 X 4		4					
*170	409494001	Screw 3.57		1					
171-201	413584002	Sinker plate complete set		1					
171-190	413585001	Sinker plate arm assembly		1					
171	413587001	Sinker plate arm		1					
172	413393000	Waving thread guide, right		1					
173	413394000	Waving thread guide, left		1					
174	413641000	Sub yarn guide, right		1					
175	413642000	Sub yarn guide, left		1					
176	412049006	+ - screw 3.18 X 3.5		2					
177	413395000	Brush plate		2					
*178	410003001	Latch opening brush, right		1					
*179	410004001	Latch opening brush, left		1					
180	413396000	Latch presser plate, right		1					
181	413397000	Latch presser plate, left		1					
*182	037280616	Screw		4					
183	412049006	+ - screw 3.18 X 3.5		4					
184	413398001	Sinker plate, right		1					
185	413400001	Sinker plate, left		1					
186	412049006	+ - screw 3.18 X 3.5		6					
187-189	413402001	Rubber wheel assembly		6					
187	413403001	Rubber wheel 35		6					
188	410970001	Holder		6					
*189	409621001	+ - screw		6					
*190	405325001	Washer		6					
191-195	413586001	Double yarn feeder assembly		1					
191	413588001	Double yarn feeder		1					
192	413408000	Magnet holder plate		1					
193	413409000	Magnet, right		1					
194	413410000	Magnet, left		1					
195	062630606	Fastening screw 2.38 X 6		2					
196	407450004	Yarn feeder knob		1					
197	413683000	Magnet		1					
198	413684001	Magnet collar		2					
*199	060660806	+ - screw 3.18 X 8		2					
200	413444001	Rubber plate, right		1					
201	413445001	Rubber plate, left		1					

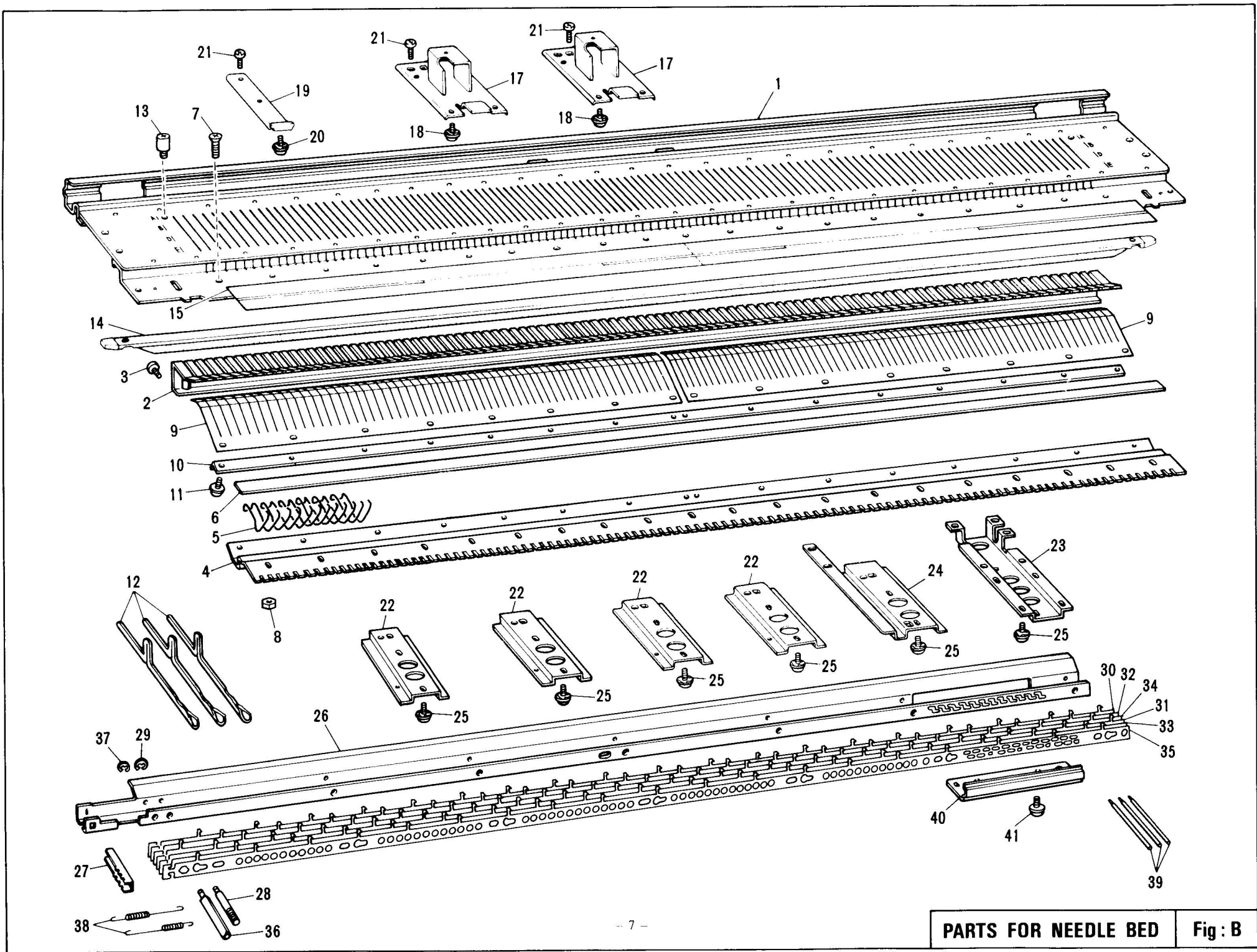

PARTS FOR NEEDLE BED **Fig: B**

PARTS FOR NEEDLE BED

Ref. No.	Parts No.	Description	Revised	Q'ty	Ref. No.	Parts No.	Description	Revised	Q'ty
B- 1	413416101	Needle bed assembly		1					
2	413421000	Needle bed lower plate		1					
*3	060660506	+ - screw 3.18 X 5		11					
4	413422100	Needle bed comb plate		1					
5	413423001	Gate peg		58					
6	413639001	Tape		1					
7	061660806	+ - screw 3.18 X 8		20					
8	021660206	Nut		20					
9	413424001	Needle retaining spring		2					
10	413425000	Needle retaining spring reinforce plate		1					
*11	410072001	Screw with washer		16					
12	413426001	Plain needle 9p		114					
13	413436001	Stud for end needle		2					
14	413427002	Needle presser bar assembly		1					
15	413430001	Needle position indicator		1					
*17	407565001	Carrying case reinforce plate A		2					
*18	409197001	Screw with washer		4					
*19	407116000	Carrying case reinforce plate B		1					
*20	409197001	Screw with washer		1					
*21	060660406	+ - screw 3.18 X 4		5					
22	413433000	Lower holder plate		4					
23	413434100	Stay, right		1					
24	413435000	Stay, center		1					
*25	409197001	Screw with washer		14					
26-38	413466001	Needle selector plate holder assembly		1					
26-27	487374001	Needle selector plate holder		1					
28	413470001	Shaft A		7					
*29	048025346	Snap ring		7					
30	413471001	Needle selector plate, 1		1					
31	413472001	Needle selector plate, 2		1					
32	413473001	Needle selector plate, 3		1					
33	413474001	Needle selector plate, 4		1					
34	413475001	Needle selector plate, 5		1					
35	413476001	Needle selector plate, 6		1					
*36	408172001	Shaft B		1					
*37	048025346	Snap ring		1					
*38	408086001	Needle selector plate spring		6					
39	413630001	N.S.P. operation lever		24					
*40	408099001	Operation lever presser		1					
*41	409197001	Screw with washer		2					

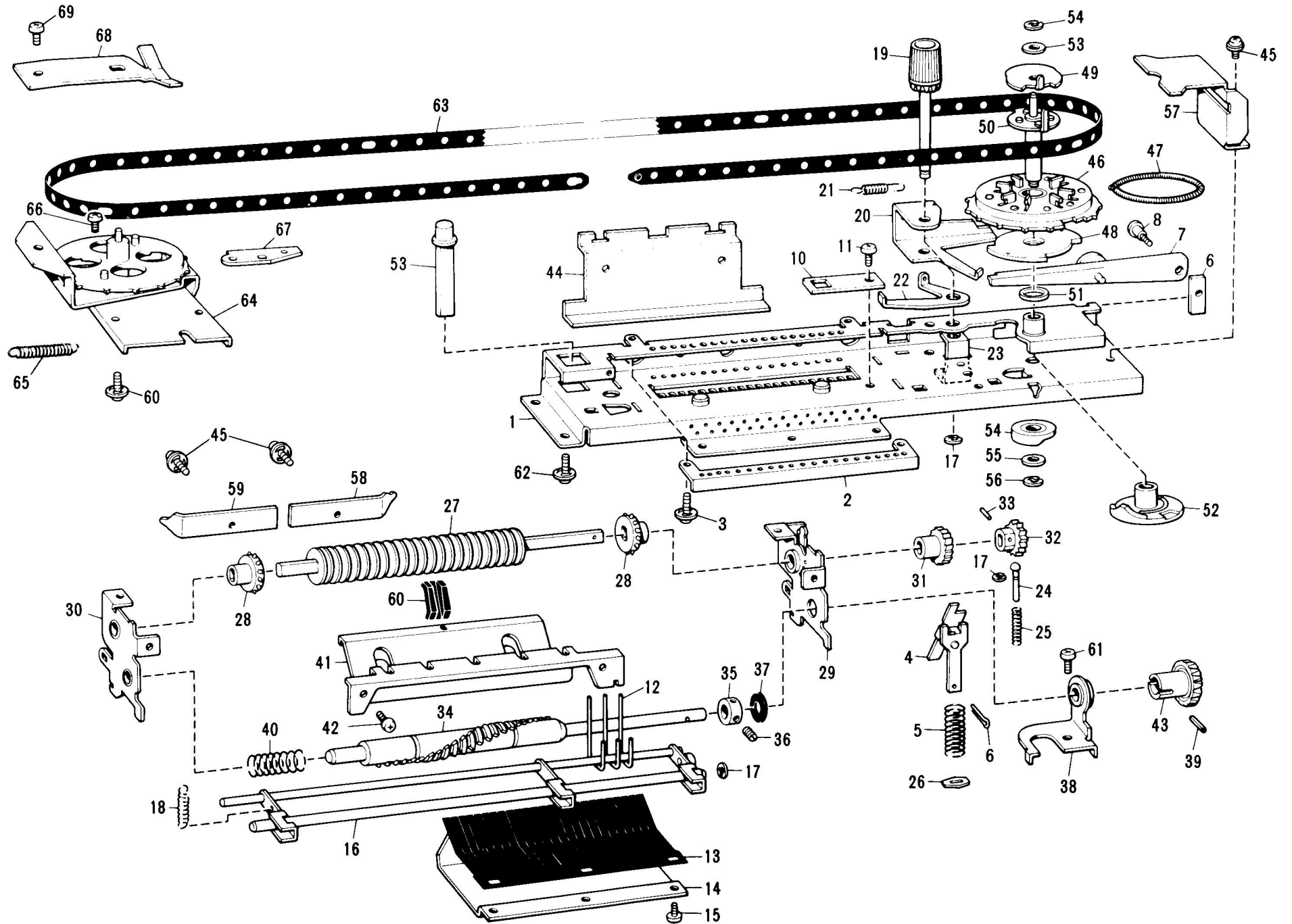

PARTS FOR NEEDLE SELECTOR UNIT

Ref. No.	Parts No.	Description	Revised	Q'ty	Ref. No.	Parts No.	Description	Revised	Q'ty
C- 1-61	413438002	Needle selector unit		1	*45	409197001	Screw with washer		2
1	413440001	Needle selector unit body		1	46	413454001	Clutch wheel assembly		1
*2	409679000	Card reader adjuster plate		1	*47	410017001	Clutch spring		1
*3	409197001	Screw with washer		2	48	413458000	Clutch gear		1
*4	409665001	Ratchet assembly		1	*49	407205001	Clutch cam B		1
*5	407145001	Ratchet operation plate spring		1	50	413459001	Clutch cam A		1
*6	045100802	Split pin		1	51	413462001	Clutch collar		1
*7	408529001	Card feeding lever assembly		1	*52	408082000	Card feeding cam		1
*8	408534001	Stud screw		1	53	408065008	Push button		1
*9	407197000	Card feeding adjuster plate		1	*54	408083000	Card reader release cam		1
*10	408068001	Card reader guide stopper		1	*55	025350333	Washer		2
*11	060660406	+ - screw 3.18 X 4		1	*56	048025346	Snap ring		2
*12	407152001	Card reader		24	57	413463000	Timing belt guide plate, right		1
*13	408315001	Card reader spring		1	*58	408309001	Spring plate R		1
*14	408213000	Card reader spring presser plate		1	*59	408308001	Spring plate L		1
*15	060660406	+ - screw 3.18 X 4		3	*60	407467000	Card guide pin holder		1
*16	408069001	Card reader release plate assembly		1	*61	060660606	+ - screw 3.18 X 6		1
*17	048020346	Snap ring		1	*62	409197001	Screw with washer 3.18 X 4		5
*18	407161001	Spring for card reader release plate		1	63	413464001	Timing belt		1
19	411458003	Card feeding knob assembly		1	64-67	413595002	Pully assembly		1
20	408535000	Intermittent feeding lever		1	*65	410016001	Belt tension control spring		1
*21	408536001	Intermittent feeding lever spring		1	*66	406397001	Screw with washer		2
22	408537000	Change lever		1	*67	410071000	Pully adjusting plate		1
*23	407193000	Card feeding Knob stopper cam		1	*68	407597001	Brake spring		1
*24	407179001	Card position guide pin		1	*69	060660406	+ - screw 3.18 X 4		1
*25	407180001	Spring		1					
*26	407464000	Ratchet spring stopper ring		1					
27-42	413442001	Card feeding unit		1					
*27	407162001	Card roller		1					
*28	407164001	Feeding gear		2					
*29	409673001	Card roller holder right assembly		1					
*30	408075001	Card roller holder, left assembly		1					
*31	407176000	Ratchet wheel		1					
*32	407177000	Card position guide gear		1					
*33	047251042	Spring pin Aw 2.5		1					
34	413443001	Rotary cam		1					
*35	137768151	Rotary cam adjuster collar		1					
*36	014400435	Stopper screw		2					
*37	409658001	Washer 8.1		1					
*38	409659001	Bevel gear stopper plate		1					
*39	047251442	Spring pin Aw 2.5		1					
*40	408165001	Rotary cam spring		1					
*41	407187001	Card guide		1					
*42	060660406	+ - screw 3.18 X 4		2					
*43	413453000	Bevel gear		1					
*44	407188000	Card reader holder		1					

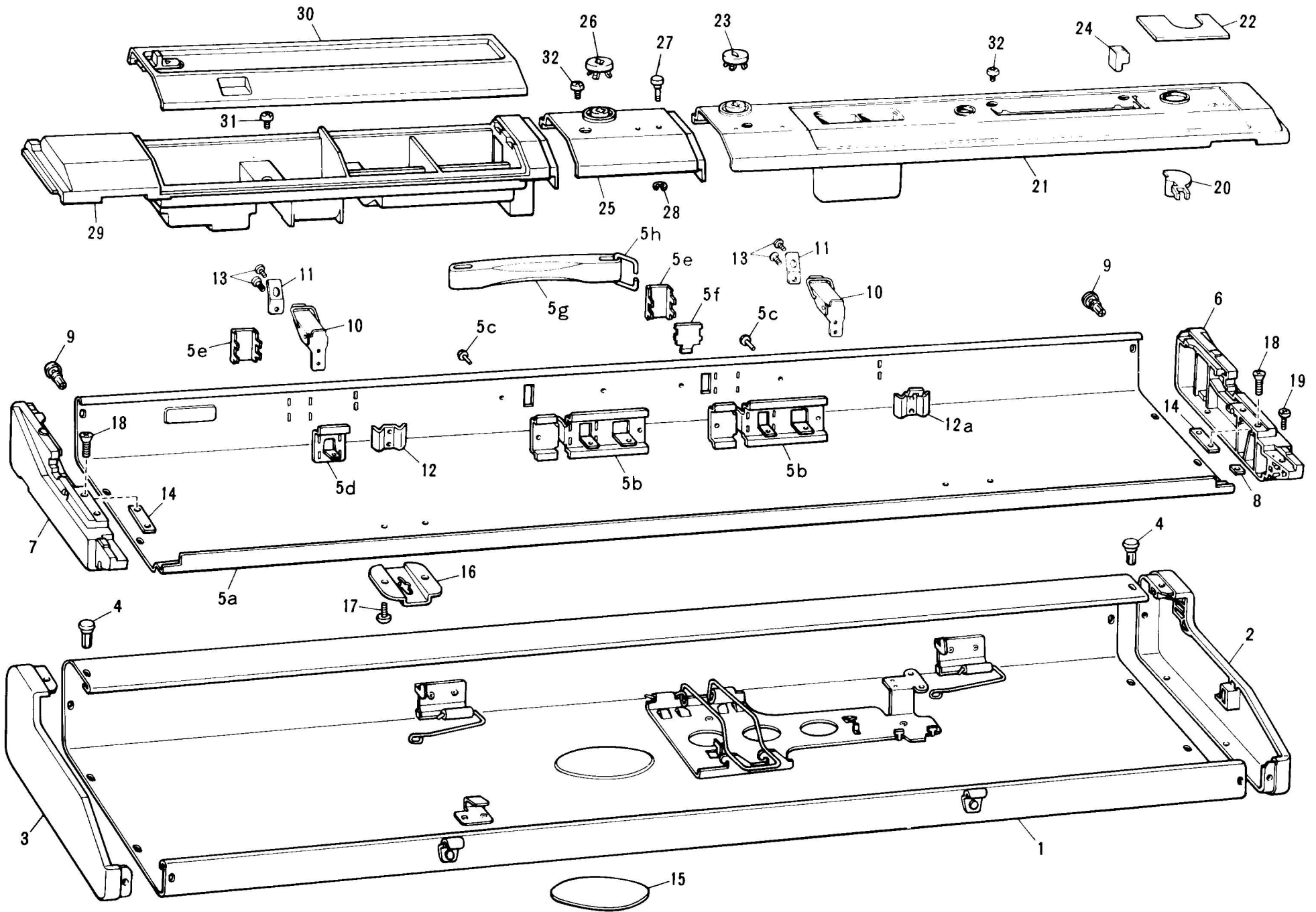

PARTS FOR CARRYING CASE

Ref. No.	Parts No.	Description	Revised	Q'ty	Ref. No.	Parts No.	Description	Revised	Q'ty
D- 1-14	413478002	Carrying case complete set KH-260		1					
1-4	413479002	Carrying case upper assembly KH-260		1					
2	413485002	Upper side plate, right		1					
3	413486002	Upper side plate, left		1					
*4	408194001	Plastic rivet		10					
5-14	413487002	Carrying case lower assembly		1					
5a-5h	413488001	Carrying case lower body		1					
6	413491002	Lower side plate, right		1					
7	413492002	Lower side plate, left		1					
*8	407252001	Square nut, 3.18		2					
*9	408194001	Plastic rivet		6					
10	404022002	Carrying case lock assembly		2					
*11	404027001	Carrying case lock spring		2					
*12	407115000	Fastening plate, left		1					
12a	413685000	Fastening plate, right		1					
*13	405658001	Fastening screw		4					
*14	411333001	Needle bed fastening plate		2					
15	413590001	Brother name plate KH-260		1					
*16	407261001	Table clamp setting plate		2					
*17	060660704	+ - screw 3.18 X 7		4					
*18	407119001	Screw		4					
*19	060660704	+ - screw 3.18 X 7		2					
20	413493001	Direction indicator plate		1					
21-23	413593001	Panel assembly		1					
*23	409995001	Reinforcing plate		1					
24	407277007	Card lock lever knob		1					
25-28	413496001	Row counter panel assembly		1					
29-30	412948002	Accessories box assembly		1					
*31	060660504	+ - screw 3.18 X 5		5					

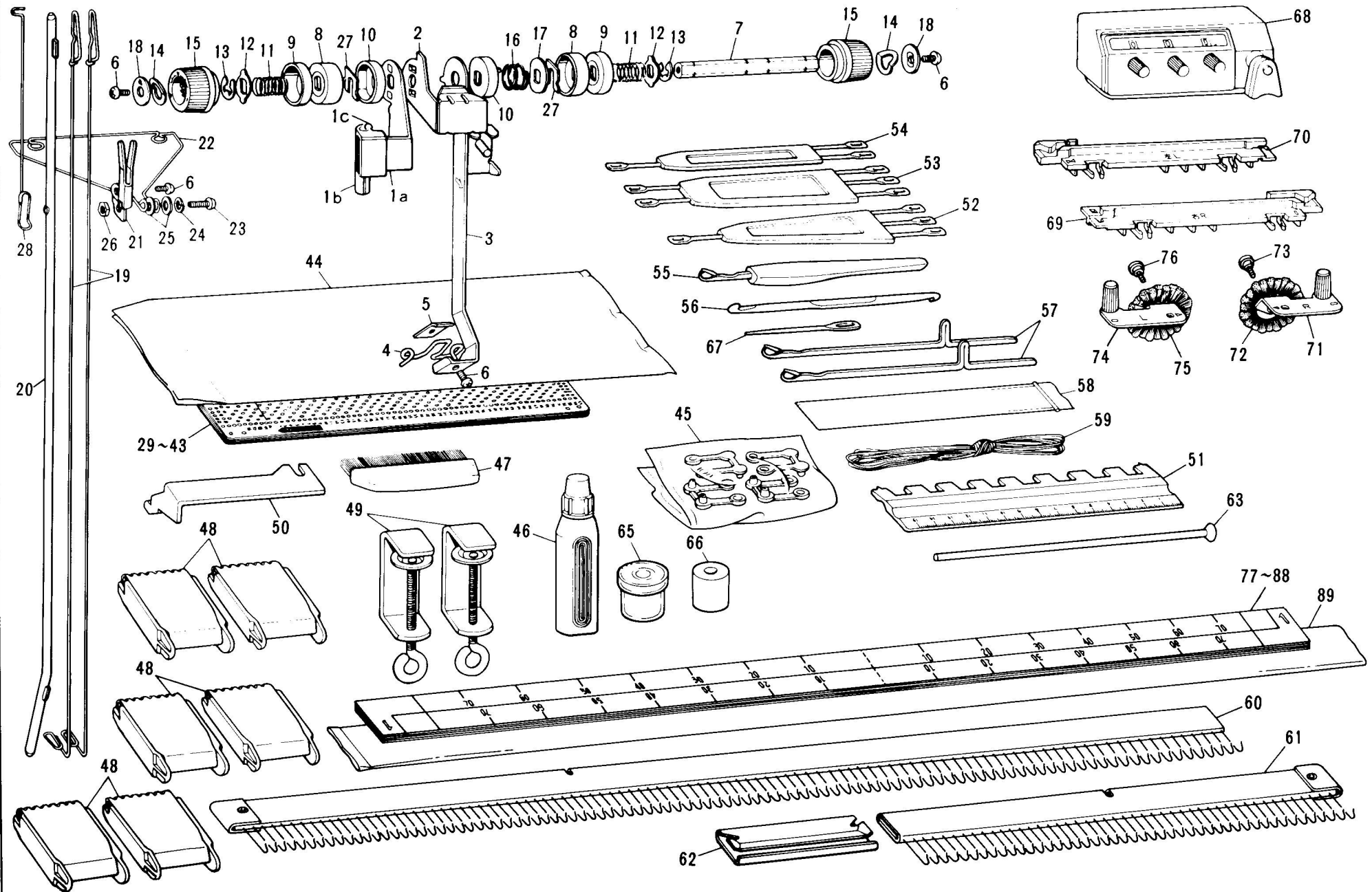

PARTS FOR ACCESSORIES

Ref. No.	Parts No.	Description	Revised	Q'ty	Ref. No.	Parts No.	Description	Revised	Q'ty
E- 1-28	413498002	Yarn tension unit assembly		1					
*19	412400001	Take-up spring		2					
28	413535001	Sub take-up spring		1					
29-44	413601001	Punch card set KH-260		1					
*45	409170001	Plastic snap (4 pcs. in one set)		1					
*46	405135004	Special knitting machine oil		1					
*47	403552004	Hand brush		1					
48	404883007	Claw weight		6					
*49	409198001	Table clamp		2					
50	413516001	Carriage lock		1					
51	411360002	1/1 needle pusher 9p		1					
52	411355002	1 X 3 transfer tool 9p		1					
53	411356002	2 X 3 transfer tool 9p		1					
54	411354002	1 X 2 transfer tool 9p		1					
55	411357002	Latch tool 9p		1					
*56	409212001	Crochet		1					
57	413426001	Plain needle 9p		2					
*58	407483000	Spare needle case		1					
*59	402389001	Cast-on thread		1					
60-62	413517001	Cast-on comb set 9p		1					
60	413551001	Cast-on comb, long 9p		1					
61	413553001	Cast-on comb, short 9p		1					
*62	411365000	Connecting plate for cast-on comb		1					
*63	407518001	Card holder pin		1					
*65-66	487221001	Yarn wax with case		1					
*67	409211001	Tapestry needle		1					
68	405209009	Row counter		1					
69	413519002	Motif knitting cam R		1					
70	413520002	Motif knitting cam L		1					
71-73	413521001	Brush wheel assembly, right		1					
74-76	413526001	Brush wheel assembly, left		1					
*77-89	412150001	Complete scale set 9p		1					