

*HuskyStar*<sup>TM</sup>  
BY HUSQVARNA VIKING

# PARTS LIST



**EM10**

1.

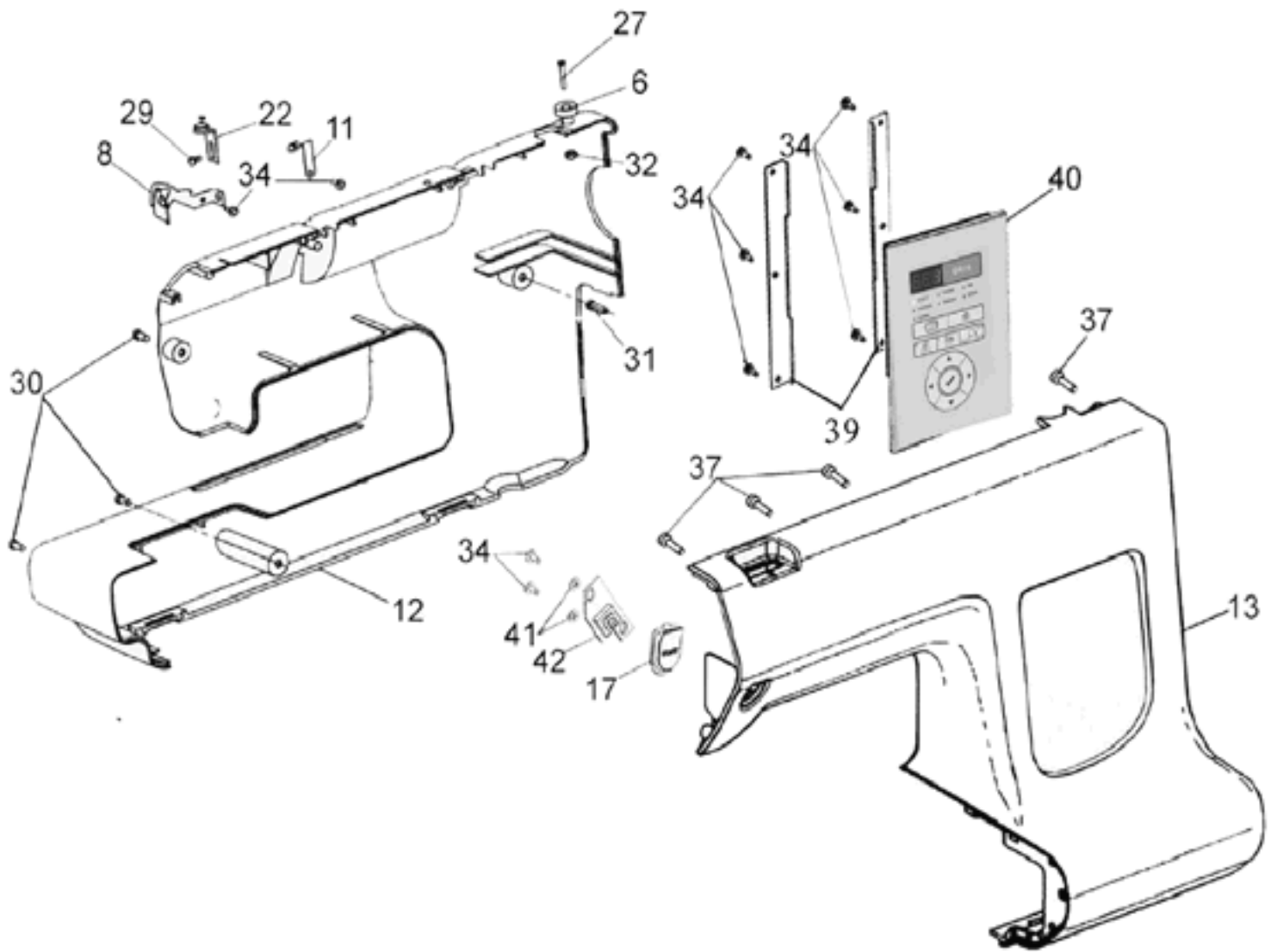

<b>Illustration</b>	<b>Part Number</b>	<b>Description</b>
1-6	416 26 08-01	Eccentric (bobbin winder stop)
1-8	416 26 10-01	Thread guide Assembly
1-11	416 26 11-01	Inline thread guide
1-12	416 26 12-01	Back cover
1-13	416 28 88-01	Front Cover
1-17	416 26 16-01	Start/stop button
1-22	416 26 20-01	Bobbin winder tensioned guide assembly
1-27	416 26 21-01	Philips screw (M3x16)
1-29	416 26 23-01	Philips Screw (M3x6)
1-30	416 26 24-01	Philips screw (M4x8)
1-31	416 26 25-01	Philips screw (M4x14)
1-32	416 26 26-01	Nut
1-34	416 28 35-01	Screw
1-37	416 28 92-01	Screw
1-39	416 28 82-01	Control panel bracket
1-40	416 28 28-01	Control panel
1-41	416 28 37-01	Flat washer
1-42	416 28 30-01	Start/stop board

1.

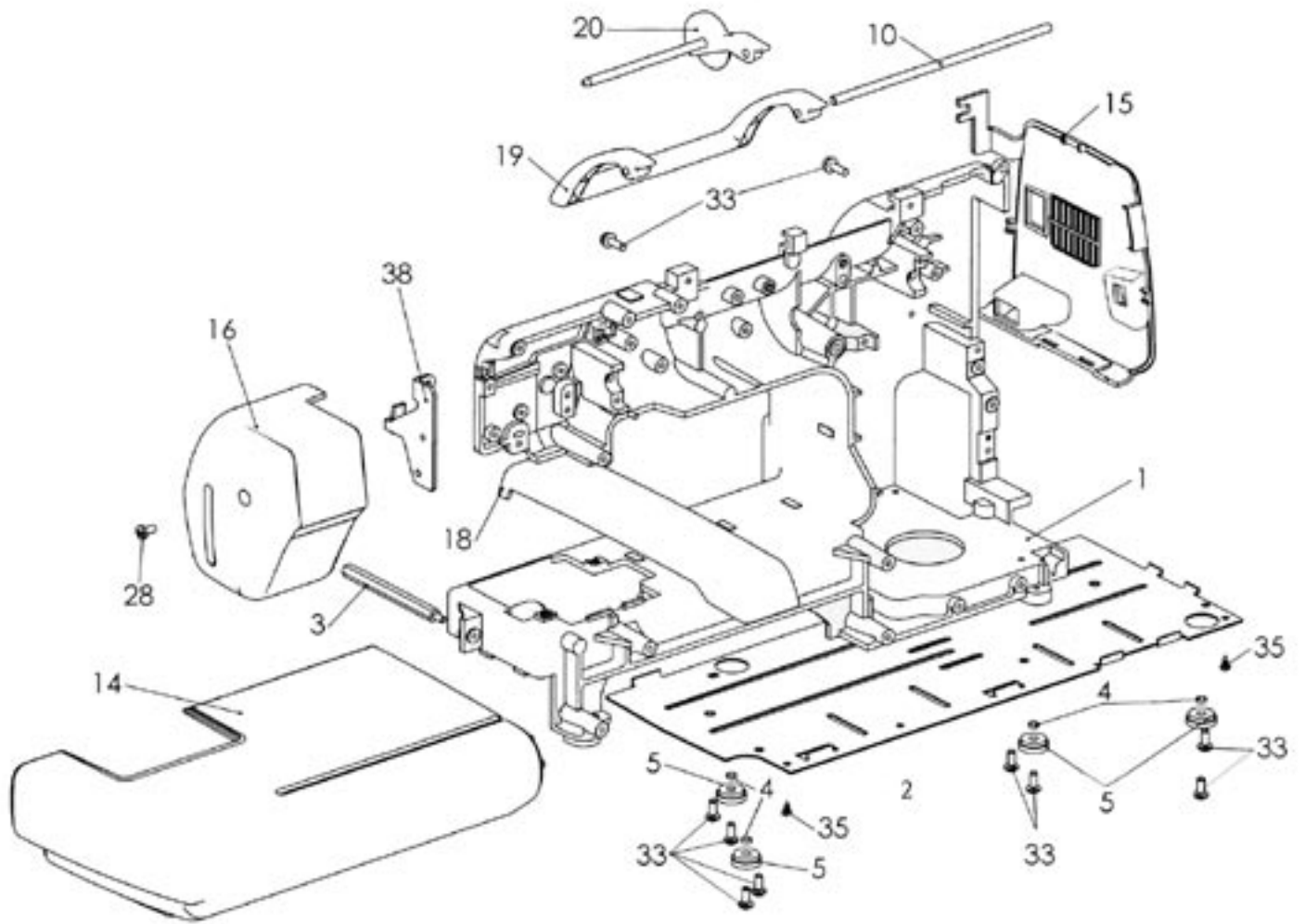

<b>Illustration</b>	<b>Part Number</b>	<b>Description</b>
1-2	416 26 04-01	Bed plate cover
1-3	416 26 05-01	Rear cover support lever
1-4	416 26 06-01	Rubber ring
1-5	416 26 07-01	Rubber washer
1-10	416 26 09-01	Handle shaft
1-14	416 26 13-01	Lower left cover
1-15	416 26 14-01	Right side cover
1-16	416 26 15-01	Left side end cap
1-18	416 26 17-01	Pantograph cover
1-19	416 26 18-01	Handle
1-20	416 26 19-01	Spool holder
1-28	416 26 22-01	Philips Screw (M4x8)
1-33	416 26 27-01	Philips Screw (M4x10)
1-35	416 26 28-01	Philips Screw
1-38	416 26 30-01	Face plate holder

2.

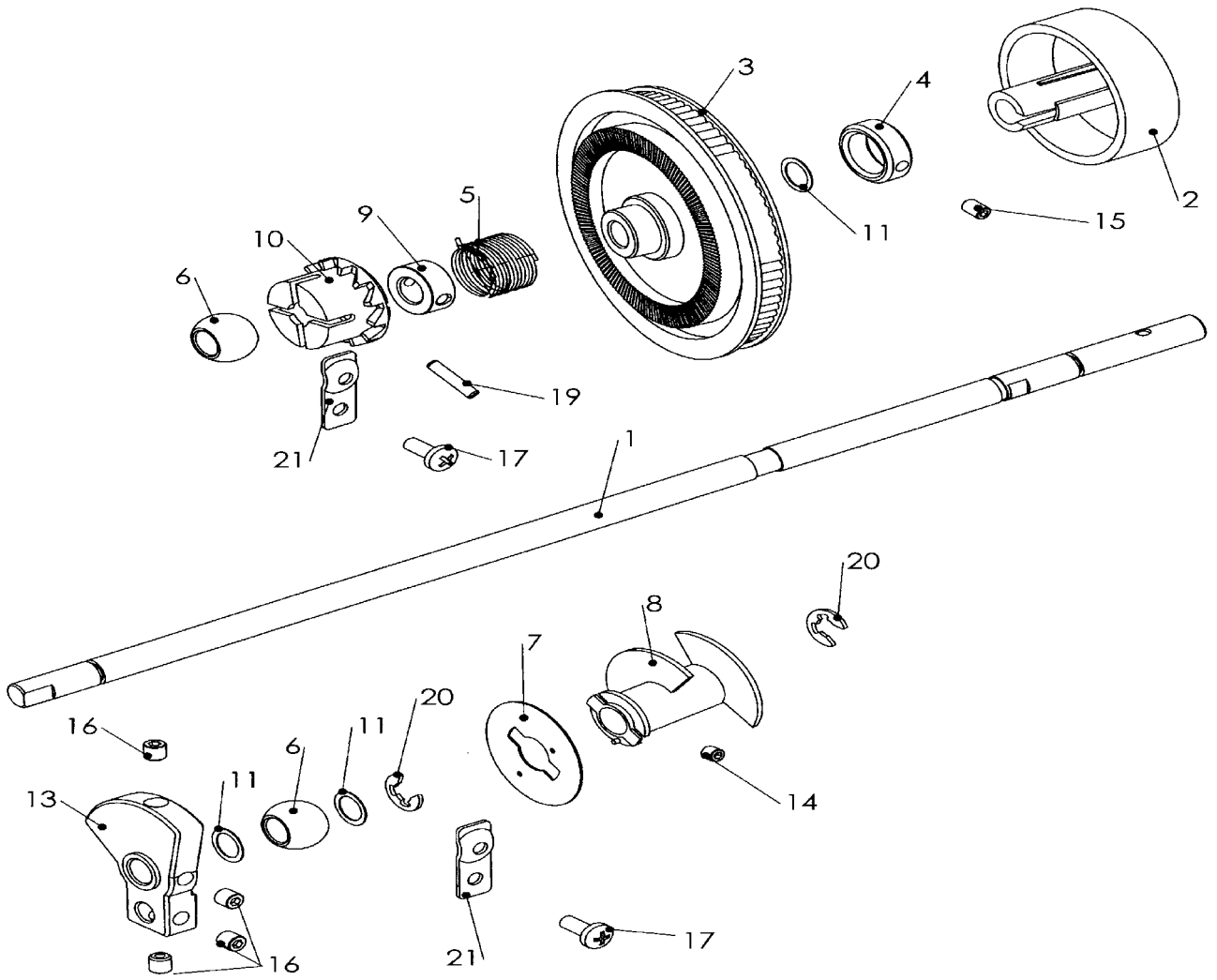

<b>Illustration</b>	<b>Part Number</b>	<b>Description</b>
2-1	416 26 31-01	Main Shaft
2-2	416 26 32-01	Hand wheel
2-3	416 26 33-01	Upper pulley
2-4	416 26 34-01	Hand wheel bushing
2-5	416 26 35-01	Spring
2-6	416 26 36-01	Main Shaft Bearing
2-7	416 26 37-01	100 Pulse Encoder Wheel
2-8	416 26 38-01	Needle Up/Movement Encoder Wheels
2-9	416 26 39-01	Motor pulley bushing
2-10	416 26 40-01	Clutch
2-11	416 26 41-01	Upper pulley washer
2-13	416 26 42-01	Needle bar crank
2-14	416 26 43-01	Allen Screw (M4 x 4)
2-15	416 26 44-01	Allen Screw (M4 x 6)
2-16	416 26 45-01	Allen Screw (M5 x 5)
2-17	416 26 46-01	Philips Screw (M4 x 10)
2-19	416 26 47-01	Pin
2-20	416 26 48-01	Snap ring
2-21	416 26 49-01	Bearing Retainer

3.

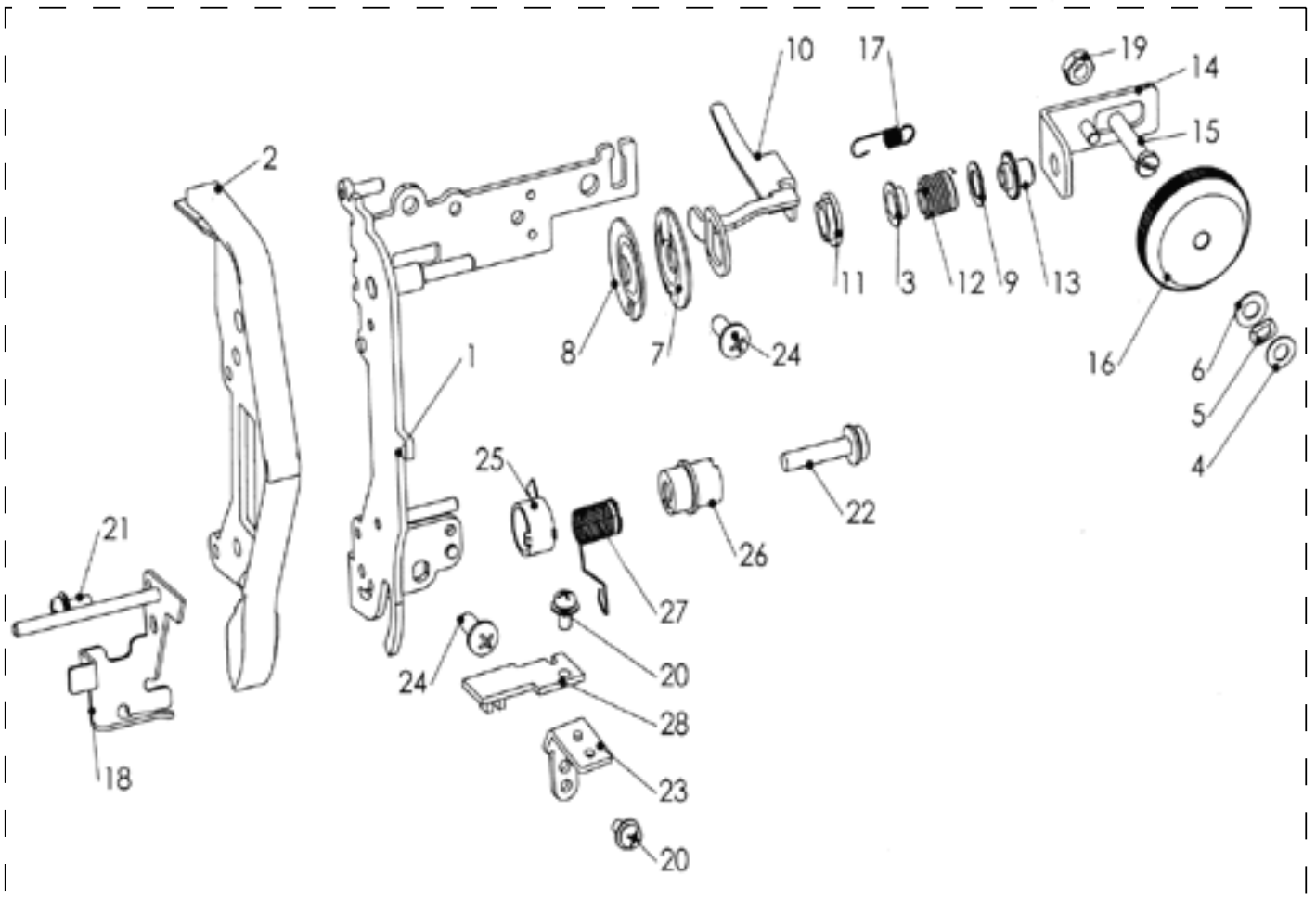



<b>Illustration</b>	<b>Part Number</b>	<b>Description</b>
	416 26 50-01	<b>Complete Thread Tension Assembly</b>
3-1	416 26 51-01	Thread clamp holder
3-2	416 26 52-01	Tension release and thread clamp cover
3-3	416 26 53-01	Spring plug
3-4	416 26 54-01	Washer
3-5	416 26 55-01	Washer
3-6	416 26 56-01	Washer
3-7	416 26 57-01	Right Tension Disk
3-8	416 26 58-01	Left Tension Disk
3-9	416 26 59-01	Washer
3-10	416 26 60-01	Thread tension release plate
3-11	416 26 61-01	Plastic bushing
3-12	416 26 62-01	Spring
3-13	416 26 63-01	Screw bushing
3-14	416 26 64-01	Thread tension moving holder assembly
3-15	416 28 83-01	Pin
3-16	416 26 65-01	Thread tension adjust dial
3-17	416 26 66-01	Spring
3-18	416 26 67-01	Thread guide
3-19	416 26 68-01	Nut (M4)
3-20	416 26 69-01	Philips screw with washer (M3 x 6)
3-21	416 26 70-01	Philips screw with washer (M3 x 8)
3-22	416 26 71-01	Philips screw with washer (M4 x 20)
3-23	416 26 72-01	Thread break sensor bracket
3-24	416 26 73-01	Philips screw (M4 x 10)
3-25,26	416 26 74-01	Thread break sensor interruptor (set)
3-27	416 26 75-01	Spring
3-28	416 26 76-01	Thread Break Sensor with Cable

# 4.

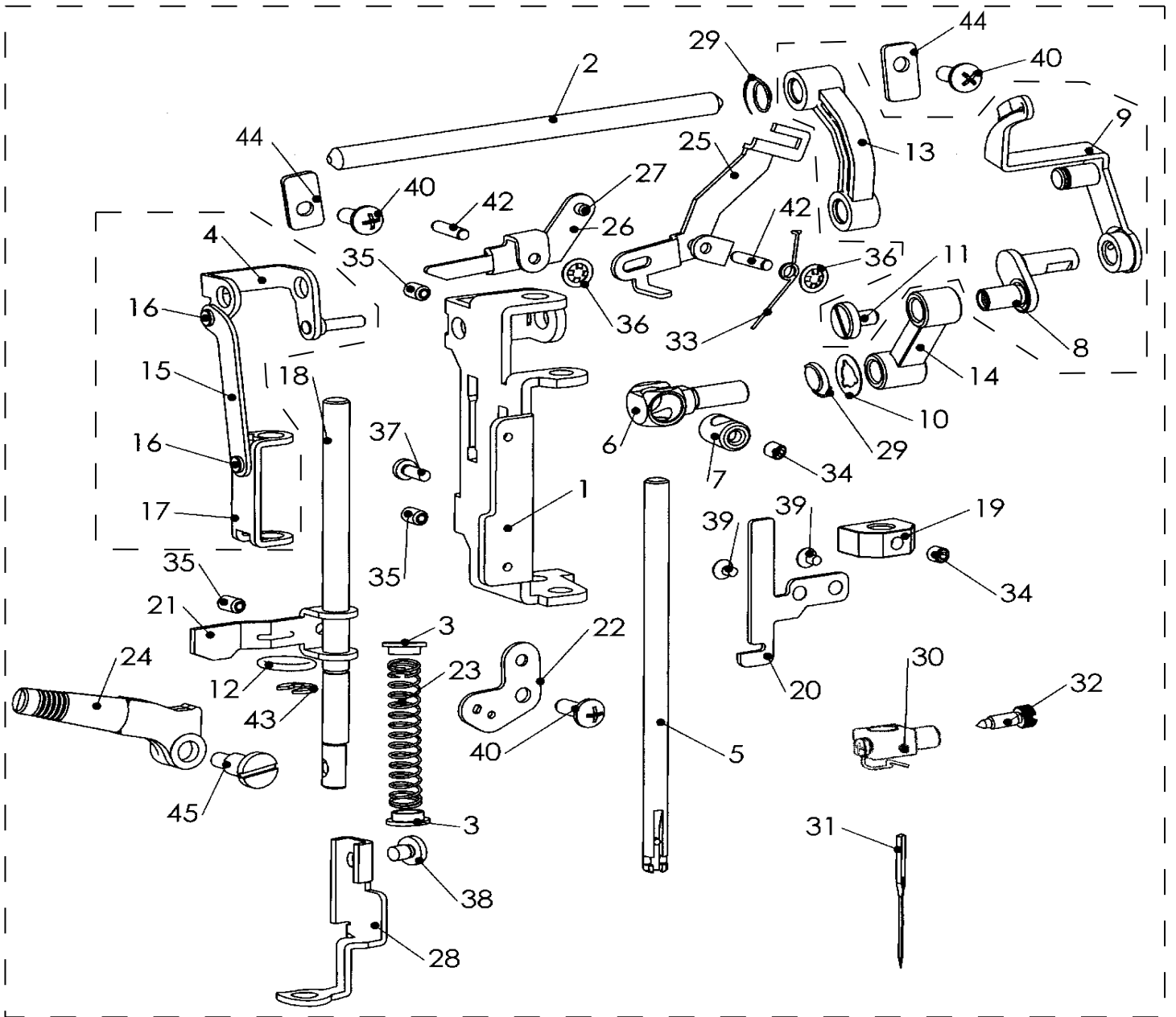
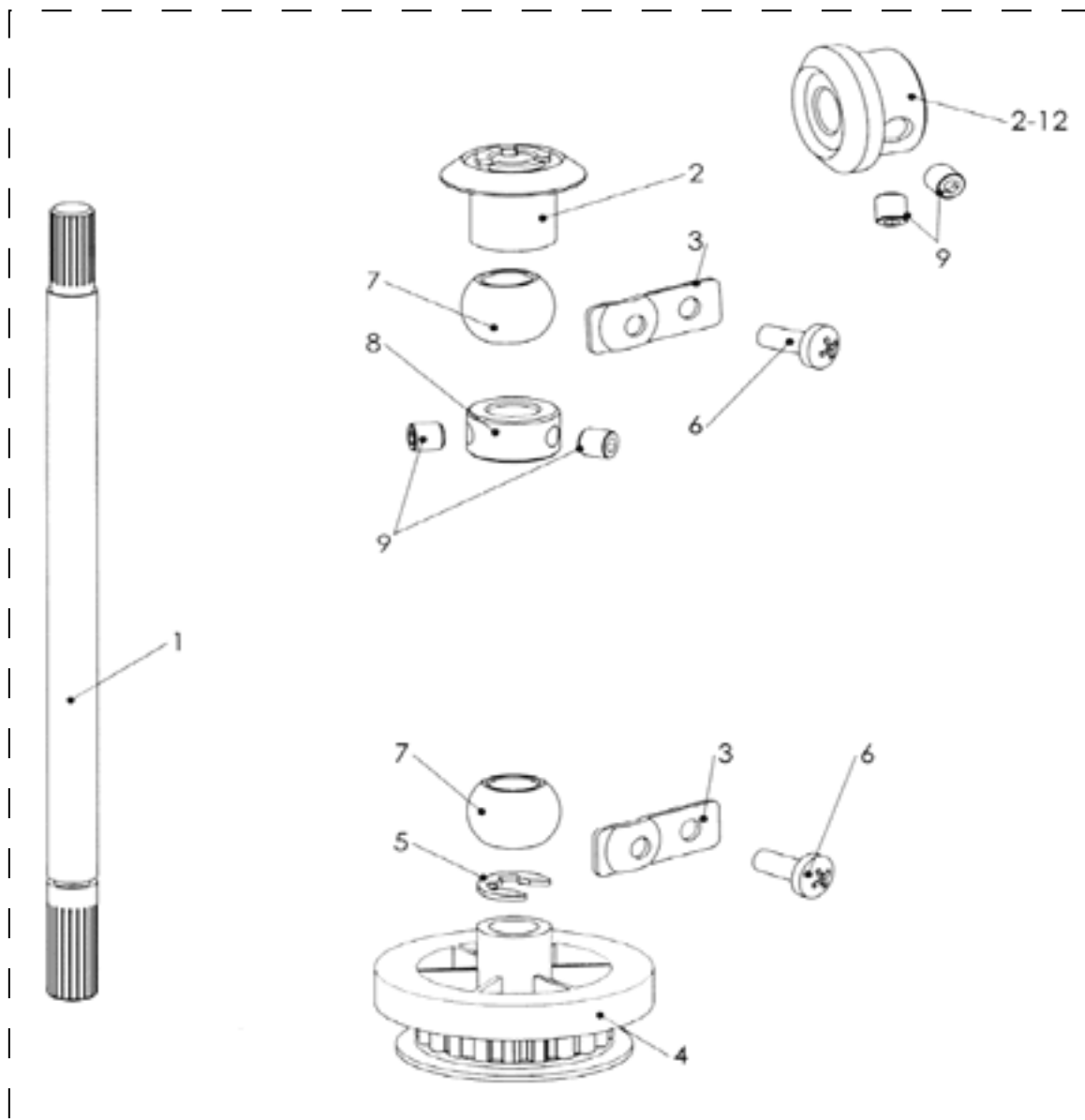

Illustration	Part Number	Description
	416 26 77-01	<b>Complete Needle Assembly</b>
4-1	416 26 78-01	Needle presser plate
4-2	416 26 79-01	Take-up shaft
4-3	416 26 80-01	Spring plug
4-4,15,16,17	416 26 81-01	<b>Swing lever assembly</b>
4-4	NA	Swing lever
4-5	416 26 82-01	Needle bar
4-6	416 26 83-01	bar connection shaft
4-7	416 26 84-01	Pin
4-8,9,11,13	416 26 85-01	<b>Take-up crank, assembly</b>
4-8	NA	Take-up crank
4-9	NA	Take-up lever
4-10	416 26 87-01	Flat washer
4-11	416 26 88-01	Screw
4-12	416 26 89-01	O-ring
4-13	NA	Take-up swing lever
4-14	416 26 91-01	Small link (4-14 are parts of 4-6)
4-15	NA	Link lever
4-16	NA	Pin
4-17	NA	Presser foot holder
4-18	416 26 92-01	Presser bar
4-19	416 26 93-01	Auto threading holder
4-20	416 26 94-01	Auto threading plate
4-21	416 26 95-01	Presser bar guide
4-22	416 26 96-01	Switch plate
4-23	416 26 97-01	Spring
4-24	416 26 98-01	Embroidery foot lift lever
4-25	416 26 99-01	Upper fork
4-26,27	416 27 00-01	Lower fork
4-28	416 27 01-01	Presser foot
4-29	416 27 02-01	Spring
4-30	416 27 03-01	Needle clamp
4-31	411 31 05-01	Needle #80 X10
4-32	416 27 04-01	Screw
4-33	416 27 05-01	Torsion coil spring
4-34	416 27 06-01	Allen screw (M4 x 4)
4-35	416 27 07-01	Allen screw (M4 x 6)
4-36	416 27 08-01	Washer
4-37	416 27 09-01	Philips screw (M3 x 8)
4-38	416 27 10-01	Philips screw (M4 x 5)
4-39	416 27 11-01	Philips screw (M2.5 x 4)
4-40	416 27 12-01	Philips screw (M4 x 10)
4-42	416 27 14-01	Pin
4-43	416 27 15-01	Snap collar
4-44	416 27 16-01	Presser plate
4-45	416 27 17-01	Screw

NA=Not available

# 5.



<b>Illustration</b>	<b>Part Number</b>	<b>Description</b>
	416 27 18-01	<b>Complete vertical shaft assembly</b>
5-1	NA	Upright shaft
5-2	NA	Bevel gear
5-3	NA	Presser plate
5-4	NA	Pulley body
5-5	NA	Snap collar
5-6	416 28 93-01	Cross screw (M4x14)
5-7	NA	Ball bearing
5-8	NA	Collar
5-9	416 28 94-01	Allen Screw (M5 x 5)
2-12	NA	Matched upper bevel gear

NA=Not available

# 6.

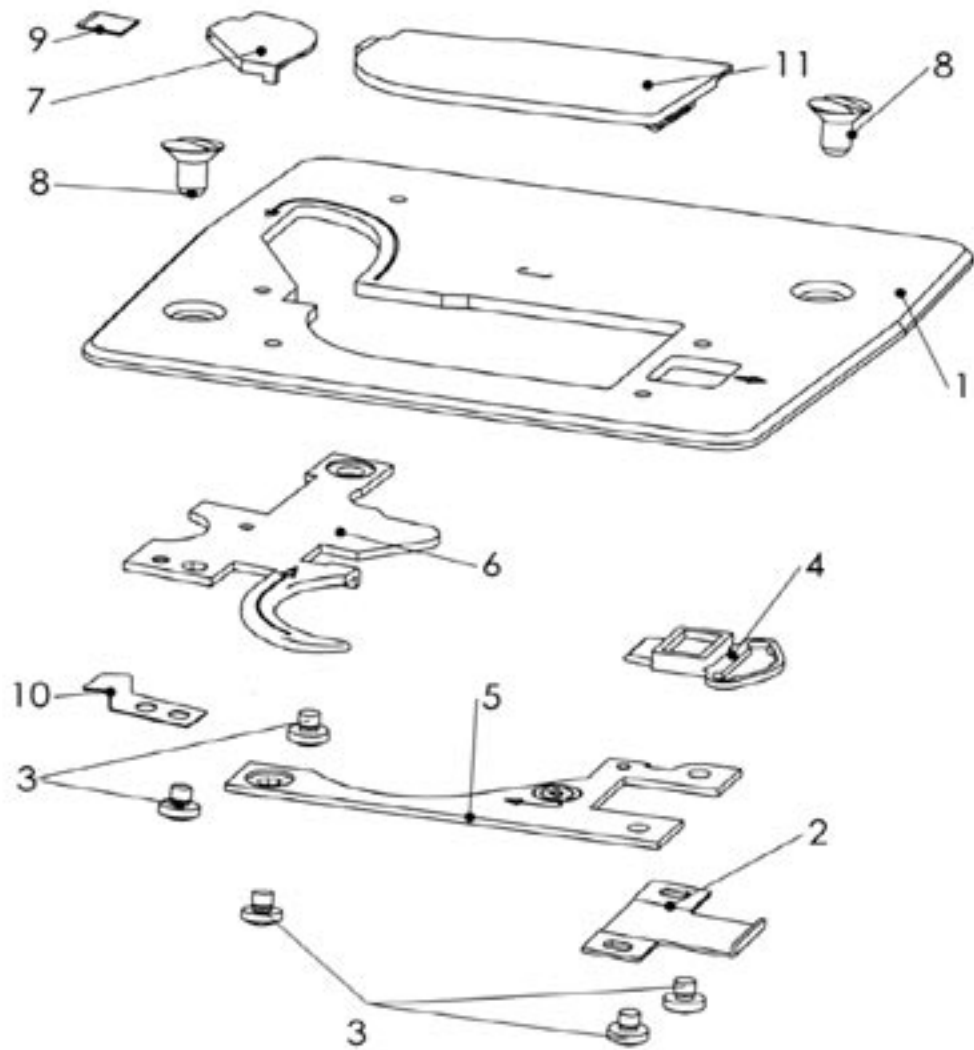

<b>Illustration</b>	<b>Part Number</b>	<b>Description</b>
6-1	416 27 19-01	Needle plate
6-2	416 27 20-01	Open button holder
6-3	416 27 21-01	Philips screw (M2.5 x 2.5)
6-4	416 27 22-01	Open button
6-5	416 27 23-01	Bobbin cover holder
6-6	416 27 24-01	Razor blade holder base
6-7	416 27 25-01	Razor blade holder
6-8	416 27 26-01	Needle plate screw
6-9	416 27 27-01	Razor blade
6-10	416 27 28-01	Bobbin cover spring
6-11	416 27 29-01	Bobbin cover

7.

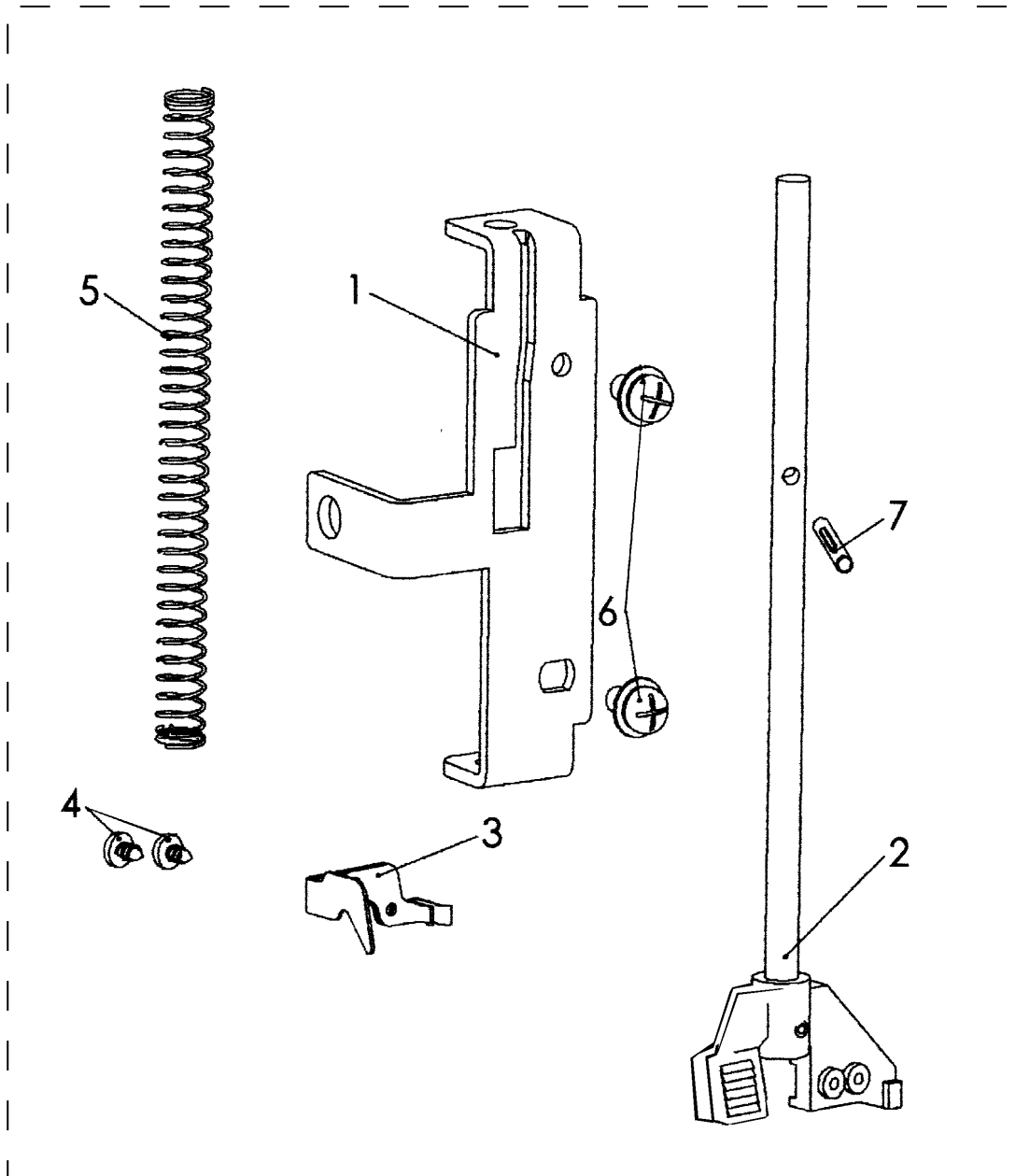



<b>Illustration</b>	<b>Part Number</b>	<b>Description</b>
	416 29 01-01	<b>Complete auto threader assembly</b>
7-1	NA	Auto threading base
7-2	NA	Auto threading lever
7-3	416 28 84-01	Auto thread guide
7-4	416 28 95-01	Cross tapping screw
7-5	NA	Spring
7-6	416 26 69-01	Screw, washer comp. (M3 x 6)
7-7	NA	Pin

NA=Not available

8.

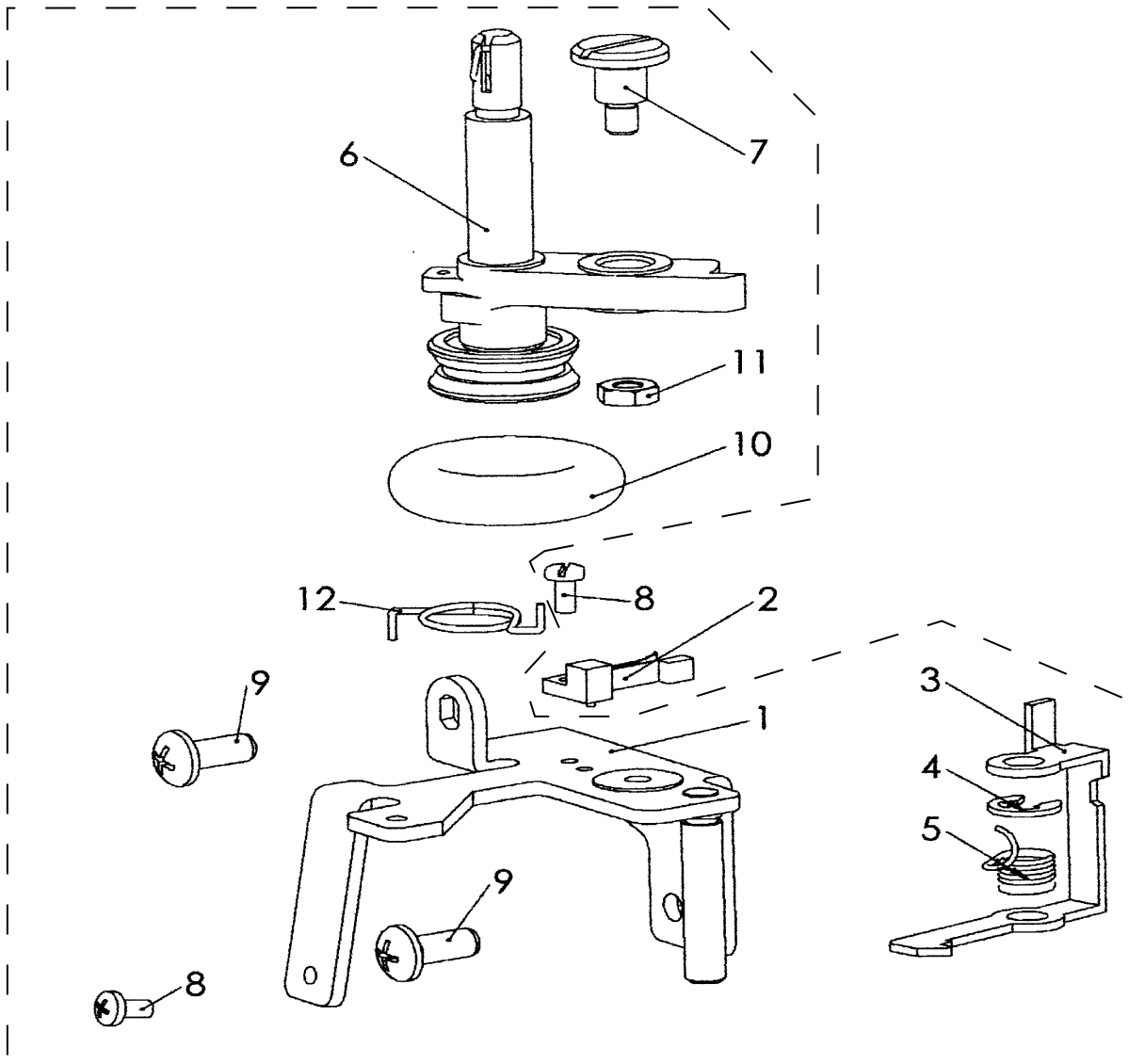

<b>Illustration</b>	<b>Part Number</b>	<b>Description</b>
8-0	416 27 31-01	Complete <b>Bobbin winder assembly</b>
8-1	NA	Thread winder plate
8-2,8	416 27 32-01	Sensor and mounting screw (M2.5 x 5)
8-3	NA	Pulley clutch hook
8-4	NA	Snap ring
8-5	NA	Torsion coil spring
8-6	NA	Thread winder holder
8-7	NA	Screw
8-9	416 28 34-01	Tapping screw (M4 x 10)
8-10	416 28 90-01	Rubber wheel
8-11	416 26 68-01	Nut (M4 )
8-12	NA	Torsion coil spring

NA=Not available

9.

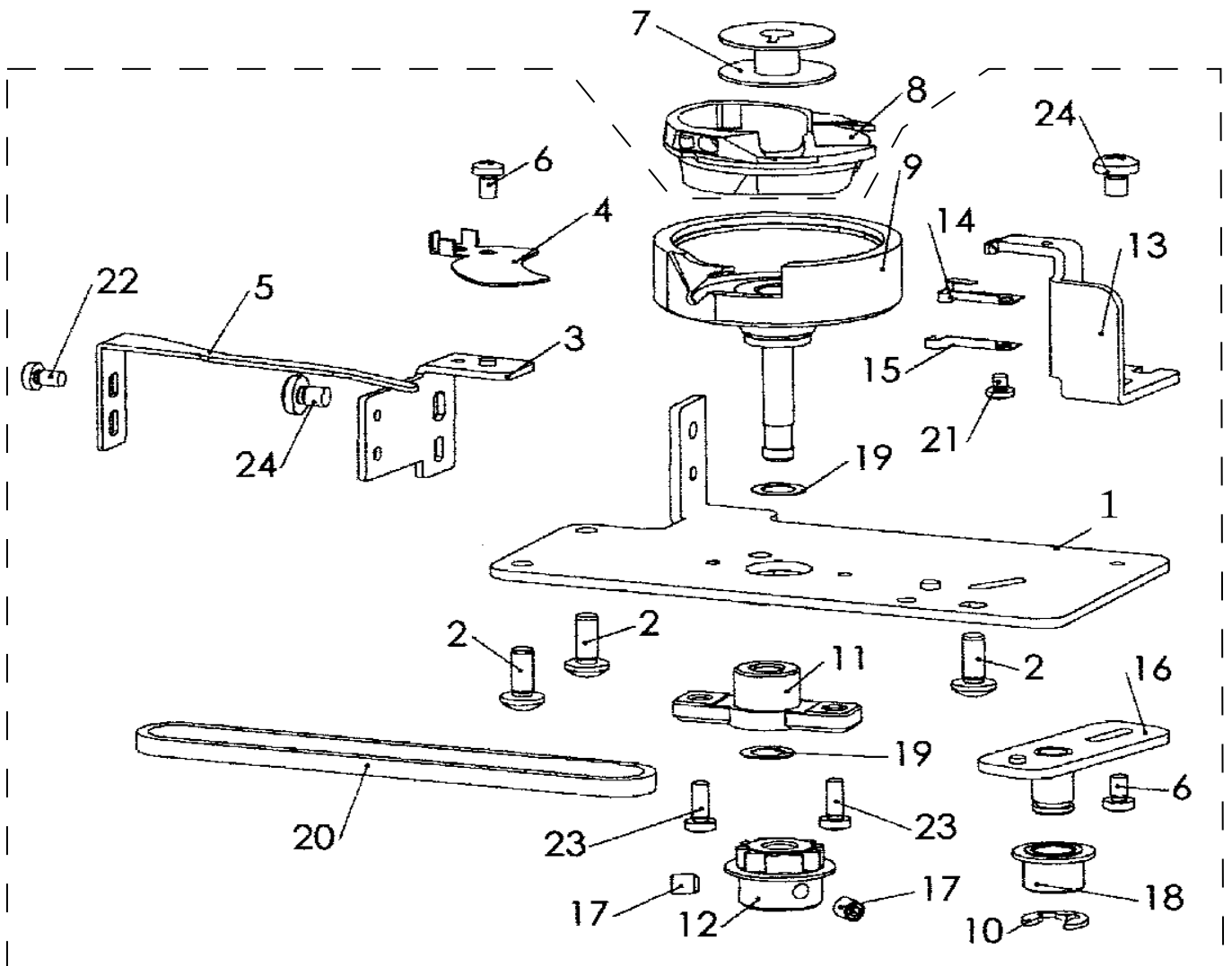

<b>Illustration</b>	<b>Part Number</b>	<b>Description</b>
	416 29 00-01	<b>Complete Hook Assembly</b>
9-1	416 27 33-01	Hook bed plate
9-2	416 27 34-01	Philips tapping screw (M4 x 10)
9-3	416 27 35-01	Plate holder
9-4	416 27 36-01	Hook thread cover
9-5	416 27 37-01	Hook thread guide
9-6	416 27 38-01	Philips screw with lock washer (M3 x 5)
9-7	416 27 39-01	Bobbin
9-8	416 27 40-01	Hook basket
9-9	416 27 41-01	Hook
9-10	416 27 42-01	Snap ring
9-11	416 27 43-01	Hook shaft holder
9-12	416 27 44-01	Synchronized pulley
9-13	416 27 45-01	Hook basket position holder
9-14	416 27 46-01	Inner hook basket position stop
9-15	416 27 47-01	Outer hook basket position stop
9-16	416 27 48-01	Synchronized pulley press wheel holder
9-17	416 27 49-01	Allen Screw (M4 x 5)
9-18	416 27 50-01	Synchronized presser wheel
9-19	416 27 51-01	Washer
9-20	416 27 52-01	Synchronized pulley belt
9-21	416 27 53-01	Philips screw (M2.5 x 3)
9-22	416 27 54-01	Philips screw (M3 x 5)
9-23	416 27 55-01	Philips screw (M3 x 8)
9-24	416 27 56-01	Philips screw (M4 x 5)

10.

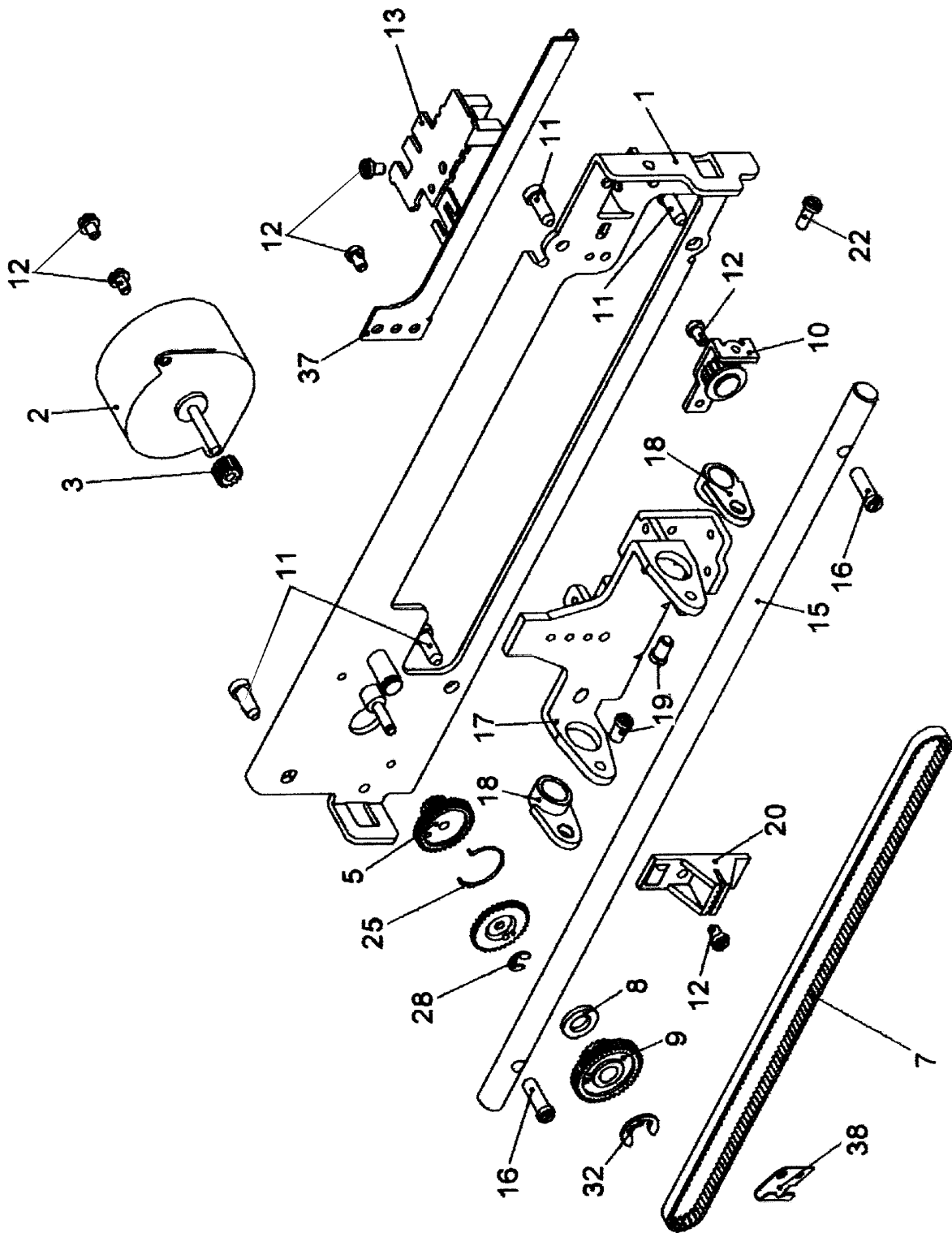

<b>Illustration</b>	<b>Part Number</b>	<b>Description</b>
10-1	416 27 57-01	X - Axis driving pillar 1
10-2,3	416 27 58-01	X - Axis step motor with Gear
10-5	416 27 60-01	Coupled gear
10-6	416 27 61-01	Antibacklash gear
10-7	416 27 62-01	X - Axis synchronized belt
10-8	416 27 63-01	Washer
10-9	416 27 64-01	Synchronized belt transmit gear
10-10	416 27 65-01	X - Belt pulley assembly
10-11	416 27 66-01	Tapping screw
10-12	416 27 67-01	Philips screw with washer (M3 x 6)
10-13	416 27 68-01	X - Axis Sensor Board (with cable)
10-15	416 27 70-01	X - Axis guide shaft
10-16	416 27 71-01	Philips screw with washer (M4 x 12)
10-17	416 27 72-01	Y - Axis drive assembly bracket
10-18	416 27 73-01	Y - Axis drive assembly bracket bushing
10-19	416 27 74-01	Philips screw (M4 x 6)
10-20	416 27 75-01	X - Axis belt clamp
10-22	416 27 77-01	Philips screw with washer (M3 x 8)
10-25	416 27 80-01	Antibacklash spring
10-28	416 27 83-01	Snap ring (small)
10-32	416 27 87-01	Snap ring
10-37	416 27 92-01	X - Axis Interruptor
10-38	416 27 93-01	Wire clamp

10.

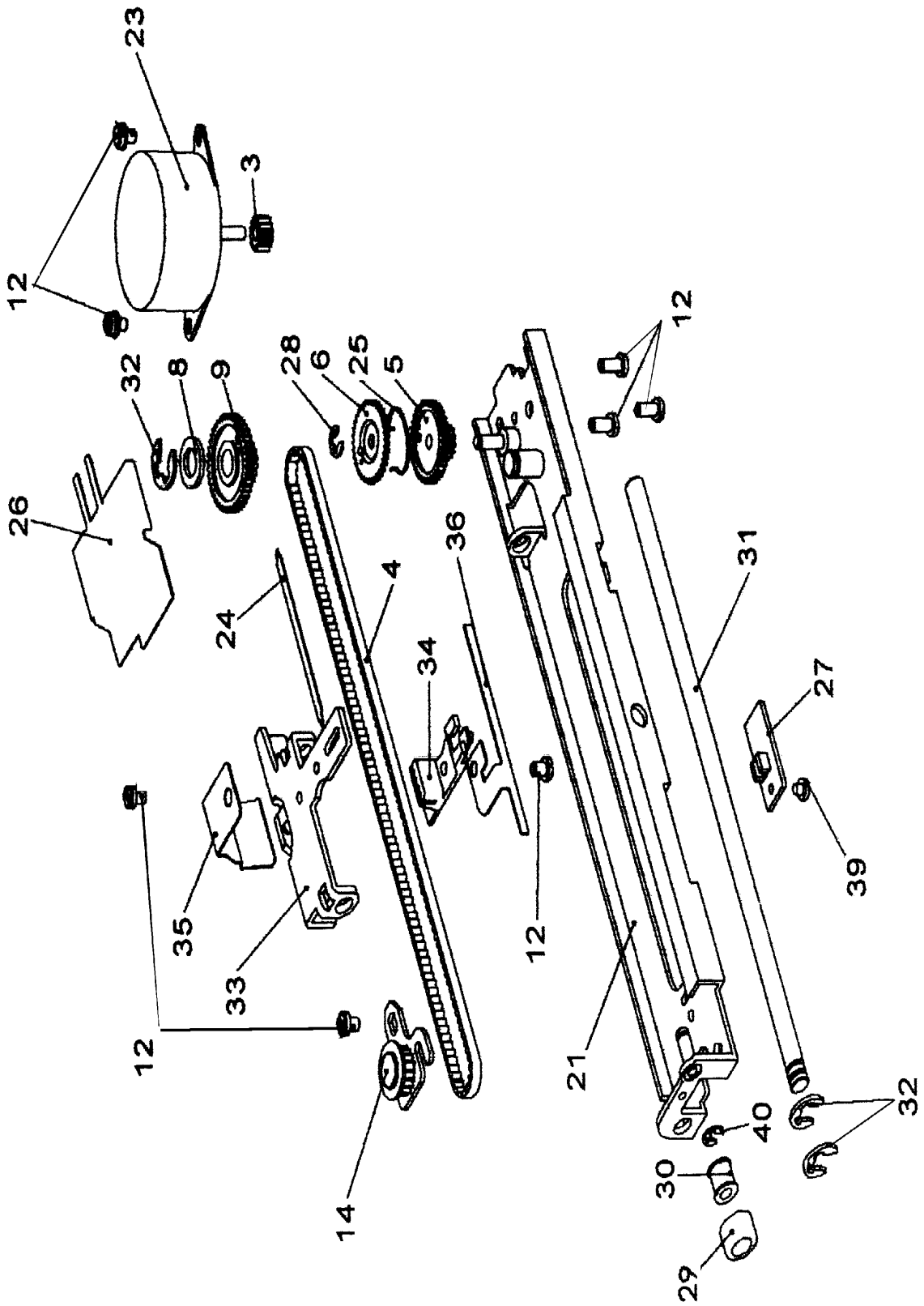



<b>Illustration</b>	<b>Part Number</b>	<b>Description</b>
10-4	416 27 59-01	Y - Axis synchronized belt
10-5	416 27 60-01	Coupled gear
10-6	416 27 61-01	Antibacklash gear
10-8	416 27 63-01	Washer
10-9	416 27 64-01	Synchronized belt transmit gear
10-12	416 27 67-01	Philips screw with washer (M3 x 6)
10-14	416 27 69-01	Y - Belt pulley assembly
10-21	416 27 76-01	Y-axis driving pillar
10-23,3	416 27 78-01	Y - Axis step motor with Gear
10-24	416 27 79-01	Spring piece
10-25	416 27 80-01	Antibacklash spring
10-26	416 27 81-01	Y - Axis gear cover
10-27	416 27 82-01	Y - Axis Sensor Board (with cable)
10-28	416 27 83-01	Snap ring (small)
10-29	416 27 84-01	Y-axis driving support wheel
10-30	416 27 85-01	Y-axis driving support wheel holder
10-31	416 27 86-01	Y - Axis guide shaft
10-32	416 27 87-01	Snap ring
10-33	416 27 88-01	Y - Axis drive bracket
10-34	416 27 89-01	Y - Axis belt clamp
10-35	416 27 90-01	Hoop Clamp Spring
10-36	416 27 91-01	Y - Axis Interruptor
10-39	416 27 94-01	Philips screw (M2.5 x 2.5)
10-40	416 27 95-01	Snap collar

# 11.

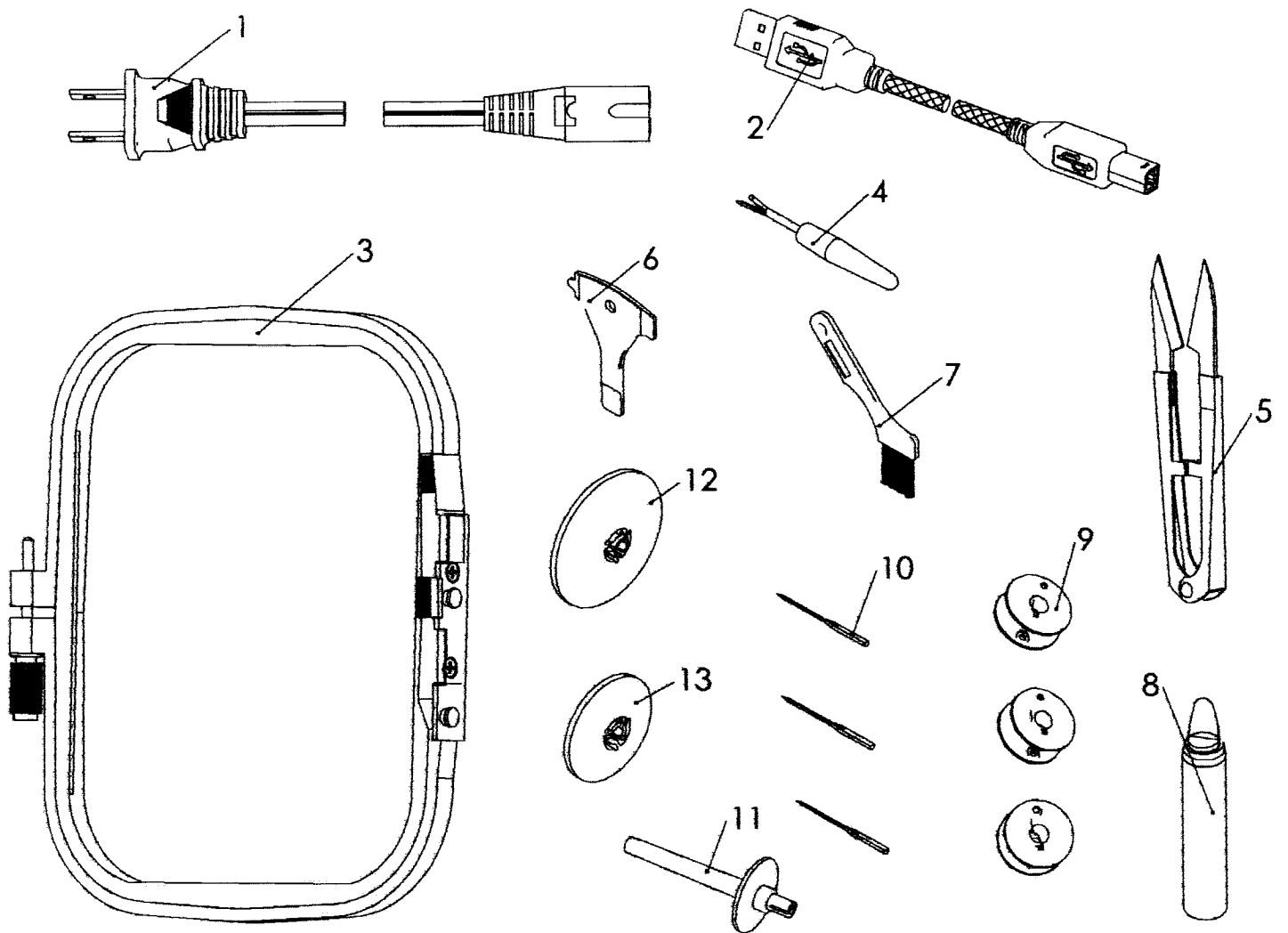

<b>Illustration</b>	<b>Part Number</b>	<b>Description</b>
	416 27 96-01	<b>Complete accessory kit</b>
11-1	412 15 78-01	Power Cord (Europe)
11-1	412 15 79-02	Power Cord (Japan)
11-1	412 15 79-03	Power Cord (USA)
11-1	412 15 80-02	Power Cord (UK)
11-1	412 15 81-01	Power Cord (Australia)
11-2	412 62 59-01	USB Wire
11-3	416 27 97-01	Hoop
11-4	416 27 98-01	Thread Ripper
11-5	416 27 99-01	Thread Nipper
11-6	416 28 00-01	Screwdriver Tool
11-7	416 28 01-01	Brusher
11-9	416 27 39-01	Bobbin
11-10, 4-31	411 31 05-01	Needle #80 x 10
11-11	416 28 02-01	Vertical Spool Pin
11-12	416 28 03-01	Large Spool Cap
11-13	416 28 04-01	Small Spool Cap
	416 28 05-01	Accessory Pouch

# 12.

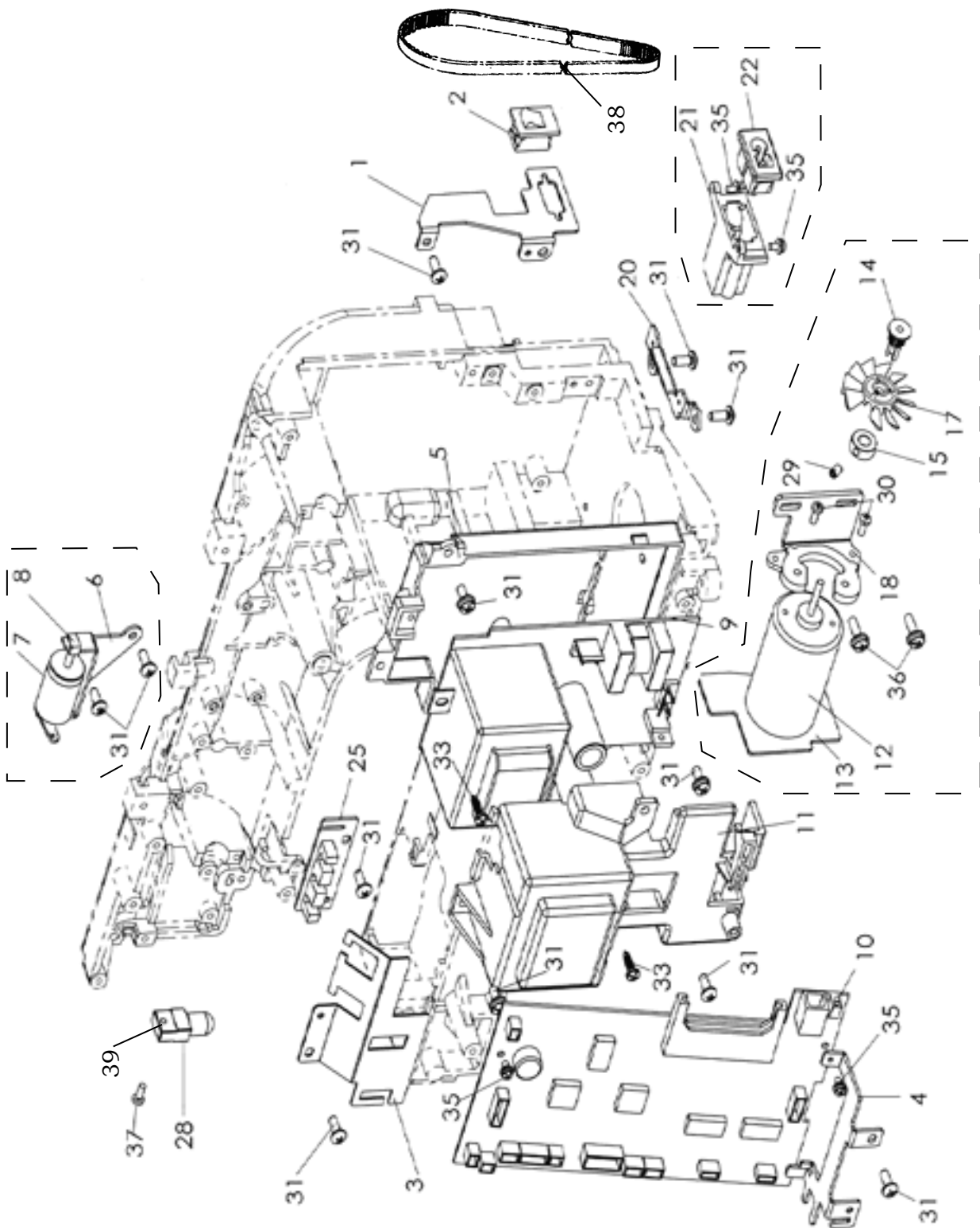

Illustration	Part Number	Description
	416 28 06-01	<b>Main motor assembly (120V 60Hz)</b>
	416 28 07-01	<b>Main motor assembly (230-240V 50Hz)</b>
12-12,13	416 28 17-01	Main motor & board (120V 60Hz)
12-12,13	416 28 18-01	Main motor & board (230-240V 50Hz)
12-14	416 28 19-01	Main shaft bushing
12-15	416 28 20-01	Main shaft bushing
12-17	416 28 22-01	Fan
12-18	416 28 23-01	Main motor installing plate & insulation board
12-29	416 28 32-01	Allen screw (M4 x 5)
12-30	416 28 33-01	Philips screw (M3 x 8)
12-36	416 28 97-01	Philips screw (M4x 14)
12-21,22,35	416 28 26-01	<b>Power connector assembly (120V 60Hz)</b>
12-21,22,35	416 28 27-01	<b>Power connector assembly (230-240V 50Hz)</b>
12-21	NA	Power plastic holder
12-22	NA	Power socket
12-6,7,8,31	416 28 14-01	<b>Solenoid assembly</b>
12-6	NA	Electromagnet plate
12-7	NA	Electromagnet
12-8	416 28 91-01	Rubber washer
12-1	416 28 08-01	On/off switch bracket
12-2,9	416 28 09-01	Power supply and on/off switch (120v 60Hz)
12-2,9	416 28 10-01	Power supply and on/off switch (230-240V 50Hz)
12-2	416 28 85-01	On/off switch (120V 60Hz)
12-2	416 28 86-01	On/off switch (230-240V 50Hz)
12-3	416 28 11-01	Shaft encoder cover
12-4	416 28 12-01	Main board bracket
12-5	416 28 13-01	Power supply plastic base
12-10	416 28 15-01	Main board
12-11	416 28 16-01	Power supply plastic cover
12-20	416 28 25-01	Power connector mounting bracket
12-25	416 28 29-01	Shaft encoders
12-28	416 28 31-01	Lamp
12-31	416 28 34-01	Screw, washer comp. (M4 x 10)
12-33	416 28 36-01	Philips screw
12-35	416 28 38-01	Screw, washer comp. (M3 x 6)
12-37	416 28 98-01	Philips screw
12-38	416 29 02-01	Drive Belt
12-39	416 29 03-01	Lamp Holder

NA=Not available

