

Spare parts
Ersatzteile
Pièces détachées
Reservdelar

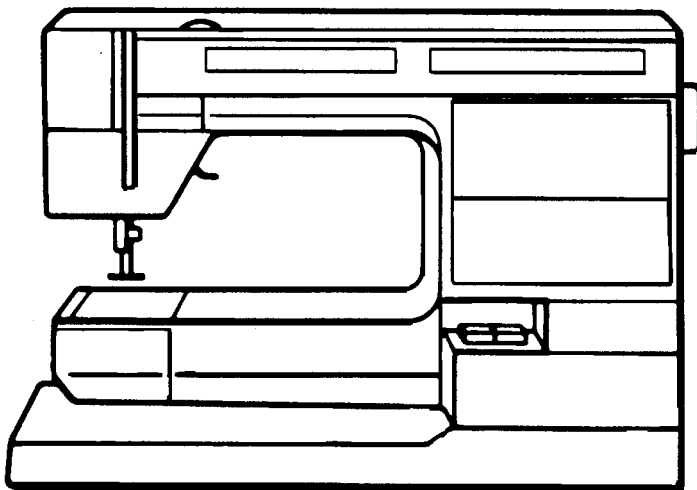

1200
1

Part no.	Description	Square	Part no.	Description	Square	Part no.	Description	Square
411 49 42-04	Driving wheel, motor ver. 2	F	412 16 56-16	Name plate LUX	A	412 33 70-01	Side motion mechanism	D
411 50 93-01	Set ring	E	412 16 59-04	Panel display	A	412 33 73-01	Toothed segment	D
411 54 38-01	Guide arm	E	412 16 61-02	Push button assembly	A	412 33 74-01	Clips	D
411 61 54-01	Thread pin	B	412 16 64-01	Code spring, cassette	A	412 33 75-01	Spring	D
411 62 41-01	Washer	F	412 16 67-01	Foil keyboard	A	412 33 97-01	Motor, version 2	F
411 63 24-02	Screw	E	412 16 69-01	Thread guide	A	412 34 59-01	Feeding guide, compl.	D
411 68 92-01	Screw	C	412 16 71-45	PC-board, guide	A	412 34 93-01	Shuttle shaft, compl.	C
411 70 54-01	Belt roll	C	412 16 72-01	Insulation plate	A	412 35 52-45	LCD-board, compl.	A
411 70 56-01	Nut	C	412 16 74-01	Thread tension device. compl.	F	412 35 53-01	Front cover, compl. HVA	A
411 70 58-05	Lower shaft, compl.	C	412 16 89-01	Spring	D	412 37 11-01	Thread real holder 20 mm	B
411 70 60-01	Worm gear	C	412 16 91-01	Clamp	D	412 37 11-02	Thread real holder 40 mm	B
						412 38 72-01	Cover	B
411 70 64-01	Cog belt	C	412 16 95-01	Block	D			
411 70 67-01	Spring	C	412 16 96-01	Dolly fork	D	412 38 96-45	PC board, version 2	A
411 70 78-01	Thread cutter	C	412 16 97-01	Spring	D	412 39 00-01	Cover plate, upper arm, compl.	B
411 70 83-02	Adjustment casing	F	412 16 99-01	Connecting rod, compl.	D	412 39 01-04	Base plate	F
411 71 59-01	Spring	F	412 17 00-02	Feeding mechan., compl.	D	412 39 15-01	Bearing sleeve	E
411 71 92-02	Cover, compl.	G	412 17 14-01	Bearing	D	412 39 18-01	Cushion	G
411 71 97-01	Spring	D	412 17 20-01	Spring	D	412 39 71-01	Attachment motor, compl. ver. 2	F
411 72 00-01	Clamp	C	412 17 21-01	Glide pin	D	412 39 84-01	Cover	A
411 72 01-01	Clamp	D	412 17 52-01	Adjusting screw	F	412 40 98-01	Screw, needle clamp	E
411 73 47-01	Binding clip	A	412 17 54-01	Regulating dial	F	412 41 02-01	Rubber foot, extension table	G
411 74 12-01	Driving wheel	C	412 17 65-01	Lamp holder	F	412 44 04-01	Cover plate (for thread tension device) ver. 2	F
411 74 45-01	Presser foot ankle	E	412 17 68-01	Dust shield	C			
411 75 00-05	Needle bar, compl.	E	412 17 77-01	Push button assembly guide	A	415 06 03-01	Foot	F
411 75 02-01	Needle clamp	E	412 17 86-45	PC-board, transformer 220-240V	F	721 41 87-70	Pin	C
411 75 03-01	Stop, needle clamp	E	412 17 86-47	PC-board, transformer 120 V	F	723 12 27-01	Screw M3x14 mm	D
411 75 04-01	Thread guide	E	412 17 86-48	PC-board, transformer 100 V	F	724 11 68-01	Screw M2x10 mm	E
411 75 60-01	Screw	E	412 17 99-01	Cover plate, free arm	B	724 11 89-01	Screw M2,5x4 mm	F
411 77 16-01	Guide spindle	C	412 18 19-01	Spring	D	724 12 89-01	Screw M4x10 mm	F
411 77 53-01	Cog belt	F	412 18 37-01	Lower thread sensor, compl.	C	724 12 92-01	Screw M4x14 mm	F
411 77 58-01	Motor, version 1	F	412 18 45-01	Foot	G	725 52 20-05	Screw M3x6 mm	F
411 77 69-01	Spring	E	412 18 68-01	Insulation plate	A	725 52 27-00	Screw M3x14 mm	E
411 77 71-01	Spring	C	412 18 72-02	Cable mat	A	725 52 32-00	Screw M3x25 mm	E
411 77 81-01	Thread guide, compl.	A	412 18 72-03	Cable mat	A	728 52 17-05	Screw M3x3 mm	D,E
411 77 95-01	Shoulder screw	A	412 19 06-01	Hook cover, compl.	C	728 52 18-05	Screw M5x6 mm	E
411 78 10-03	Light bulb	E,F	412 19 53-01	Washer	D	728 52 83-05	Screw	C
411 78 12-01	Feed dog lowering, compl.	D	412 19 55-01	Adj. nob LCD	A	728 52 87-05	Screw M4x8 mm	E
411 78 20-11	Switch, feed dog lowering	D	412 19 56-18	Panel, guide, Swedish	A	728 53 20-05	Screw M5x5 mm	C
411 78 20-12	Main switch	D	412 19 56-19	Panel, guide, Danish	A	728 73 20-01	Screw M5x5 mm	C
411 78 21-01	Lamp guard	F	412 19 56-20	Panel, guide, Finnish	A	728 83 23-05	Screw M5x8 mm	C
411 78 30-01	Screw	C	412 19 56-21	Panel, guide, Norwegian	A	731 23 10-01	Nut	D
411 78 36-01	Spring	D	412 19 56-22	Panel, guide, English	A	733 78 11-41	Quick-acting lock nut	A
411 78 38-01	Thread guide	E	412 19 56-23	Panel, guide, French	A	734 11 35-71	Washer	E
411 78 40-01	Screw	C	412 19 56-24	Panel, guide, Dutch	A	734 11 36-01	Washer	A,F
411 79 05-01	Screw	E	412 19 56-25	Panel, guide, Italian	A	734 11 40-01	Washer	F
411 83 81-01	Cable, motor	F	412 19 56-26	Panel, guide , Spanish	A	735 31 06-20	C-washer 2,3	E
411 83 88-02	Cable mat	F	412 19 56-27	Panel, guide , German	A	735 31 09-20	C-washer 5	F
411 86 86-01	Driving wheel, motor ver. 1	F	412 19 56-28	Panel, guide, Japanese	A	735 31 13-20	C-washer 8	C
411 87 75-01	Spring	B	412 19 59-01	Lamp guard	E	735 58 35-00	Locking washer	F
411 87 80-01	Attachment motor, compl.	F	412 19 79-01	Arm shaft, compl.	C	735 61 36-40	Compression ring 4 mm	D
411 88 43-01	Hold down spring	C	412 19 80-01	Pin	C			
411 88 43-01	Hold down spring	C	412 19 85-01	Step motor	F			
411 96 02-03	Screw	C	412 20 11-01	Length feeding fork, compl.	D	ACCESSORIES		
411 96 67-01	Screw 22 mm	A	412 20 27-01	Mounting clip	A	401 53 99-01	Buttonhole knife	G
			412 20 27-01	Mounting clip	D	401 55 55-01	Brush	G
411 96 68-01	Screw 7.5 mm	A	412 21 01-02	Feed dog	D	411 17 32-01	Clearance plate	G
412 00 07-01	Screw	D						
412 00 86-01	Shoulder screw	E	412 21 14-01	Screw M3x4 mm	D,E	412 08 38-46	Marking pen, neutral	G
412 00 87-01	Adjusting nut	E	412 21 14-03	Screw M3x8 mm	E	412 09 75-45	Bobbins (10)	G
412 00 88-01	Nut	E	412 21 14-06	Screw M3x14 mm	D	412 16 40-01	Needle threader	G
412 02 74-01	Bobbin winding, compl.	F	412 21 14-11	Screw M4x8 mm	A,B,C,D,F	412 26 94-01	Anniversary plate (300 year)	G
412 02 75-01	Locking ring	F	412 21 14-14	Screw M4x16 mm	D	412 28 90-01	Screw driver (small)	G
412 05 37-01	Thread cutter	B	412 22 36-45	Transformer 220 V	F	412 28 90-02	Screw driver (medium)	G
412 05 60-01	Screw M5x14 mm	F	412 22 36-46	Transformer 240 V	F	412 35 95-01	Templet omnigram	G
412 05 60-07	Screw M4x16 mm	F	412 22 36-47	Transformer 120 V	F	412 35 96-02	Templet monogram	G
412 05 60-11	Screw M3x5 mm	D	412 22 36-48	Transformer 100 V	F	412 38 10-01	Needle case	G
412 08 49-01	Hook	C	412 22 52-01	Screw	C			
412 08 84-01	Extension table compl.	G	412 22 53-01	Bushing	C	CASSETTES		
412 08 87-01	Nut	C	412 22 55-01	Micro switch, compl.	E	412 28 16-02	Cassette case 1200	G
						412 17 29-21	Cassette A pattern	G
412 09 68-02	Finger	C	412 22 70-01	Lamp holder, compl.	E	412 17 29-22	Cassette B block letters	G
412 09 69-01	Latch	C	412 22 80-01	Setting screw	D	412 17 29-23	Cassette C script letters	G
412 09 72-02	Bobbin case, compl.	C	412 22 82-01	Thread take up lever, compl.	E	412 17 29-24	Cassette D pictogram	G
412 09 74-01	Thread tension spring	C	412 22 86-01	Driving wheel lower shaft	C	412 17 29-28	Cassette H hiragana	G
412 13 12-01	Light bulb LCD	A	412 22 87-01	Lever	C	412 17 29-32	Cassette L omnigram	G
412 15 00-01	Sewing head, compl.	E	412 22 98-01	Locking nut	D	412 17 29-33	Cassette M monogram	G
412 15 02-01	Lifting arm	E	412 24 53-01	Cable guide	C			
412 15 11-01	Plate	E	412 24 74-02	Accessory box, compl.	G	OPERATING MANUALS		
412 15 14-01	Shaft, sewing frame	E	412 25 80-01	Access. bag with brush, bobbins etc	G	412 34 62-01	Operating Man. Swe	G
412 15 15-01	Pressar bar	E	412 26 79-01	Spring	E	412 34 62-06	Operating Man. Dan	G
412 15 16-01	Spring	E	412 26 81-01	Access. bag with presserfeet etc	G	412 34 62-11	Operating Man. Fin	G
412 15 23-01	Cross head, compl.	E	412 27 14-01	Shaft, belt roll, compl.	C	412 34 62-21	Operating Man. Nor	G
412 15 28-01	Toothed segment	E	412 27 21-01	Spring,	E	412 34 62-26	Operating Man. Eng	G
412 15 29-01	Link	E	412 27 41-01	Sealing washer (for thread tension device) ver. 1	F	412 34 62-31	Operating Man. French	G
412 15 30-01	Spring	E	412 27 48-01	Shaft, pin	F	412 34 62-36	Operating Man. Dutch	G
412 15 31-02	Regulating dial	E	412 27 55-01	Cable holder	B	412 34 62-41	Operating Man. Ita	G
412 15 35-01	Needle bar frame	E	412 27 57-01	Mounting clamp	A	412 34 62-46	Operating Man. Spa	G
			412 27 74-04	Front cover, sewing head	A	412 34 62-51	Operating Man. Ger	G
412 15 53-01	Spring	E	412 27 75-01	Lifting pin, compl.	D			
412 15 54-01	Screw	E	412 27 76-01	Shaft, feed dog, compl.	D			
412 15 77-01	Cord reel	G						
412 15 78-01	Cord device, std	G	412 27 77-01	Thread tension set, compl.	F,G	PRESSERFEETS		
			412 27 78-01	Thread holder, compl.	B	411 73 89-01	Buttonhole foot C	G
412 15 79-01	Cord device, USA-Can	G	412 27 79-01	Thread guide, compl.	B	411 73 91-01	Pressar foot D	G
412 15 80-02	Cord device, UK	G	412 27 80-01	Thread cutter, sewing	G	411 73 95-01	Edge guide	G
412 15 81-01	Cord device, Australia	G	412 27 91-01	Foot control, compl.	B	411 85 27-01	Pressar foot J	G
412 15 93-01	Washer	E	412 28 05-05	Screw	G	411 85 30-01	Pressar foot H	G
412 15 98-01	Spring	G	412 31 89-01	Control unit	B	412 00 16-01	Pressar foot, decorative stitches	G
412 16 00-04	Foot control, cpl. without cable	G	412 32 04-01	Cover for transformer 220 V	F	412 03 73-01	Pressar foot A	G
412 16 33-01	Spring	C	412 32 04-02	Cover for transformer 240 V	F	412 03 74-01	Pressar foot B	G
412 16 34-01	Screw	C	412 32 04-03	Cover for transformer 120 V	F	412 17 84-01	Buttonhole meter, compl.	G
412 16 35-01	Bobbin centre	C						
412 16 37-01	Bearing ring, hook cover	C	412 32 04-04	Cover for transformer 100 V	F	412 34 65-01	Pressar foot S	G
			412 32 34-01	Step motor	E	412 38 05-01	Zipper foot E	G
412 16 43-01	Hook cover	C	412 32 34-02	Step motor	D			
412 16 47-01	Handwheel	C	412 32 88-45	Program memory 1200	A	GREASE , OIL		
412 16 48-01	Screen	C	412 32 88-47	Program memory 1200 Japan	A	411 04 71-01	Oil Anderol 500 (in 12 ml phial)	G
412 16 53-01	Handle, compl.	A	412 33 11-45	PC-board, version 1	A	411 54 73-01	Oil Tellus 68 (in plastic cushion)	G
412 16 55-04	Name plate HVA	B	412 33 62-01	Cog wheel	D	412 09 42 -01	Grease, black LM47	G
412 16 55-07	Name plate LUX	B	412 33 65-01	Stitch plate, compl.	C	412 18 24-01	Oil Tellus 68 (in 1 liter bottle)	G
412 16 56-09	Name plate Vik. # 1	A	412 33 66-01	Washer	C			
412 16 56-10	Name plate Husqvarna 1200	A						
412 16 56-11	Name plate Husqvarna # 1	A						

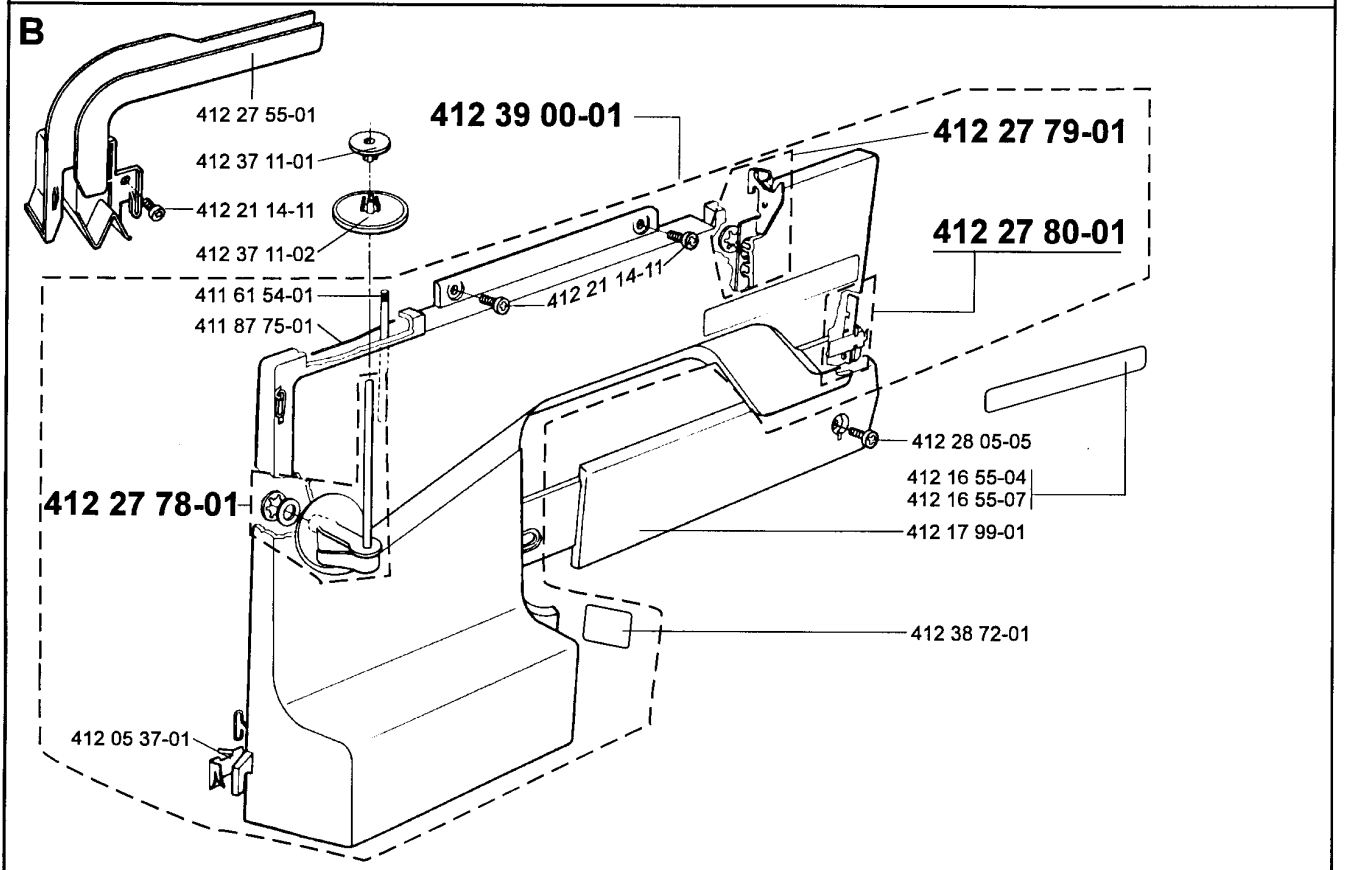
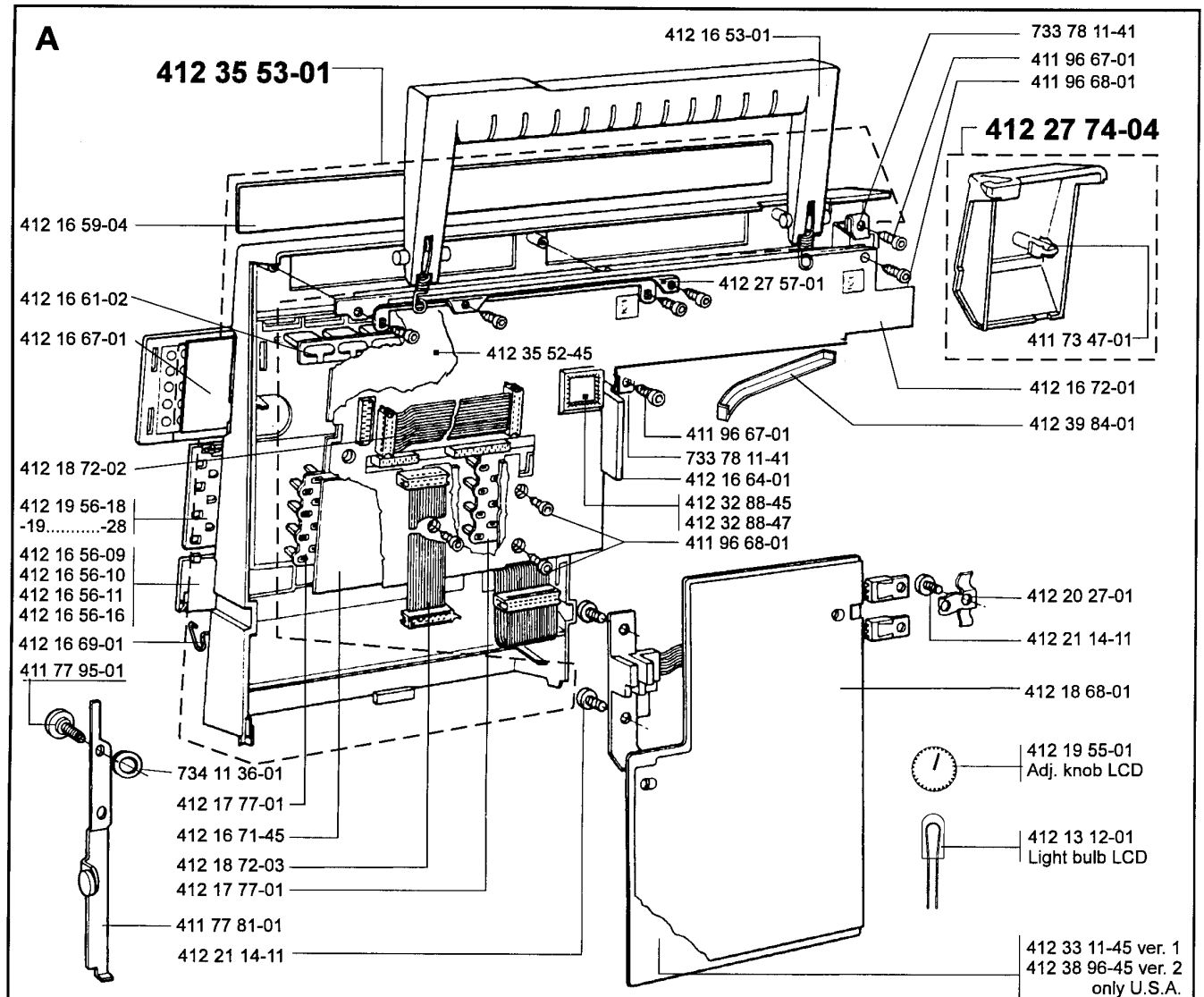

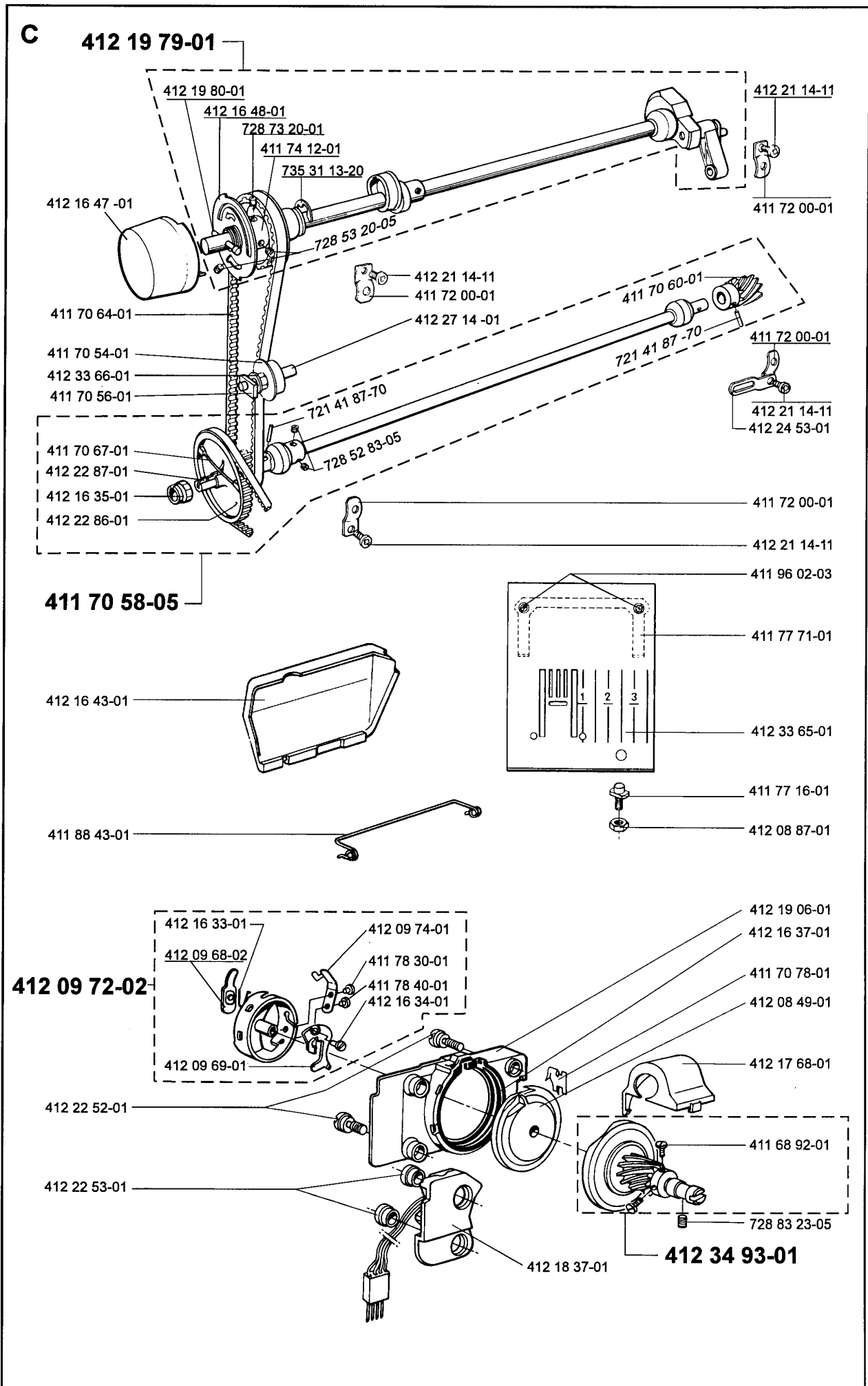

D

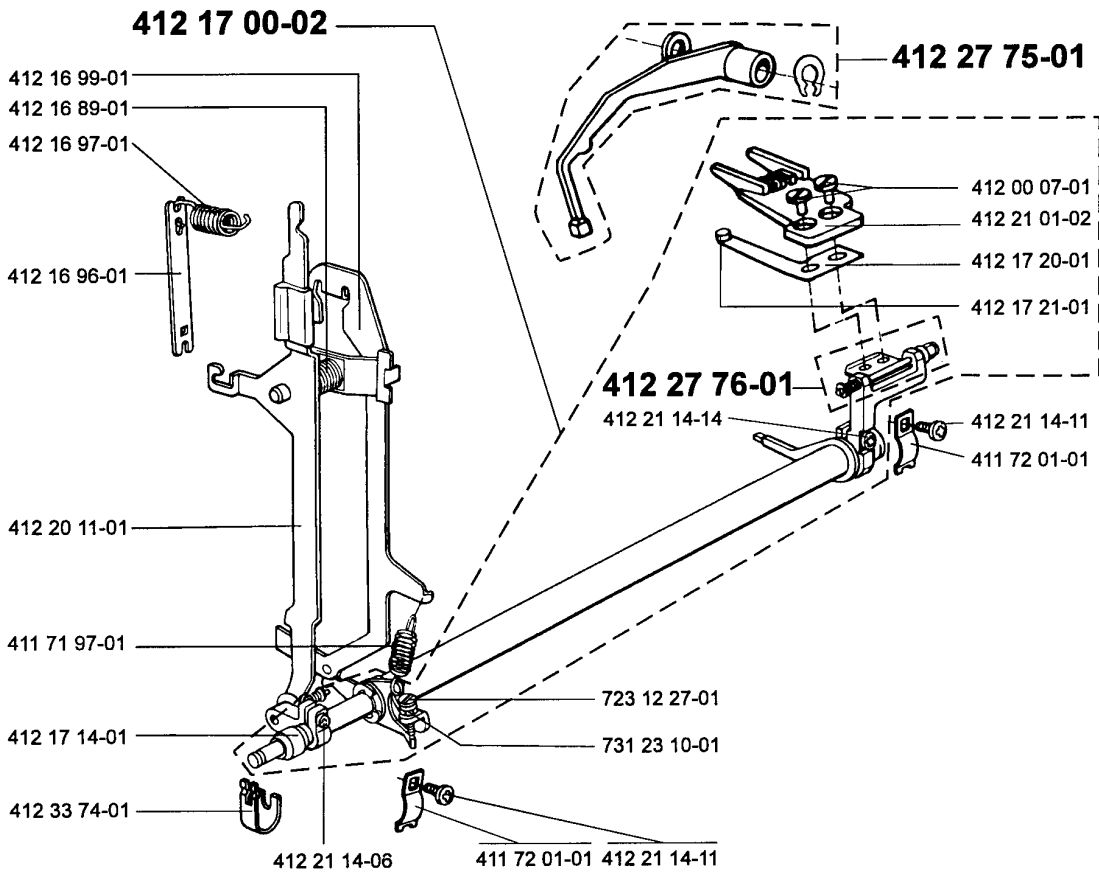

412 34 59-01

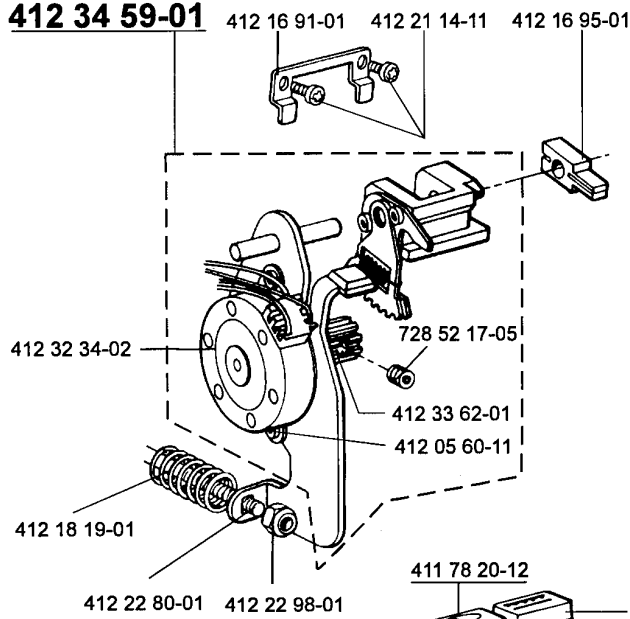

412 33 70-01

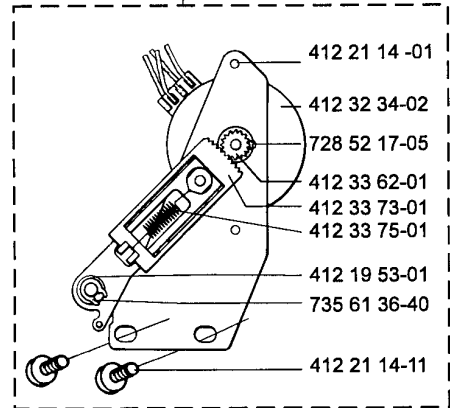

411 78 20-12



412 21 14-11

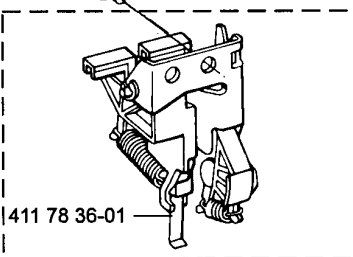

411 78 12-01

E

412 15 00-01

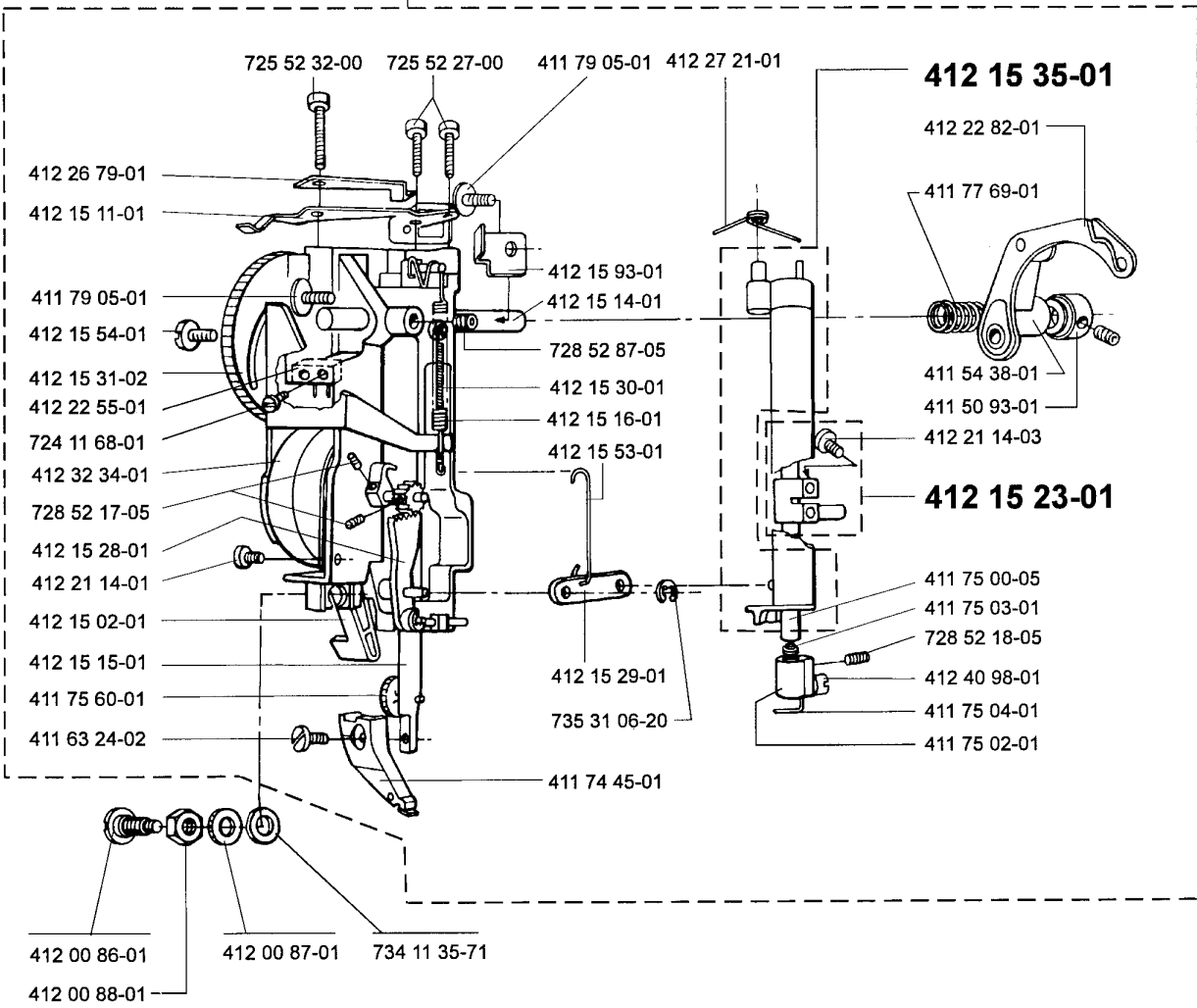

412 22 70-01

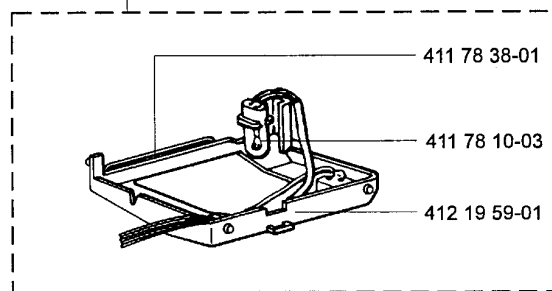

F

412 16 74-01

412 27 77-01

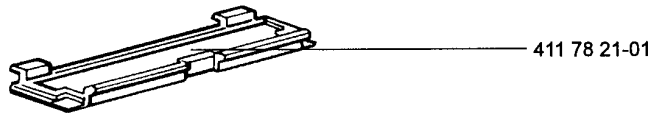
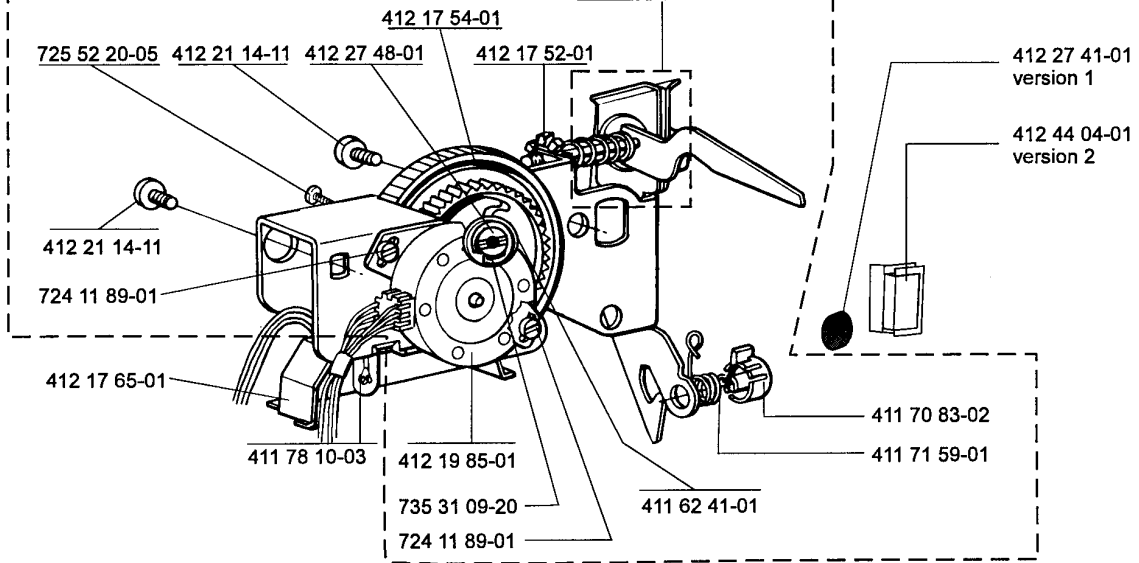

411 77 58-01

412 33 97-01
only U.S.A.

412 39 01-04

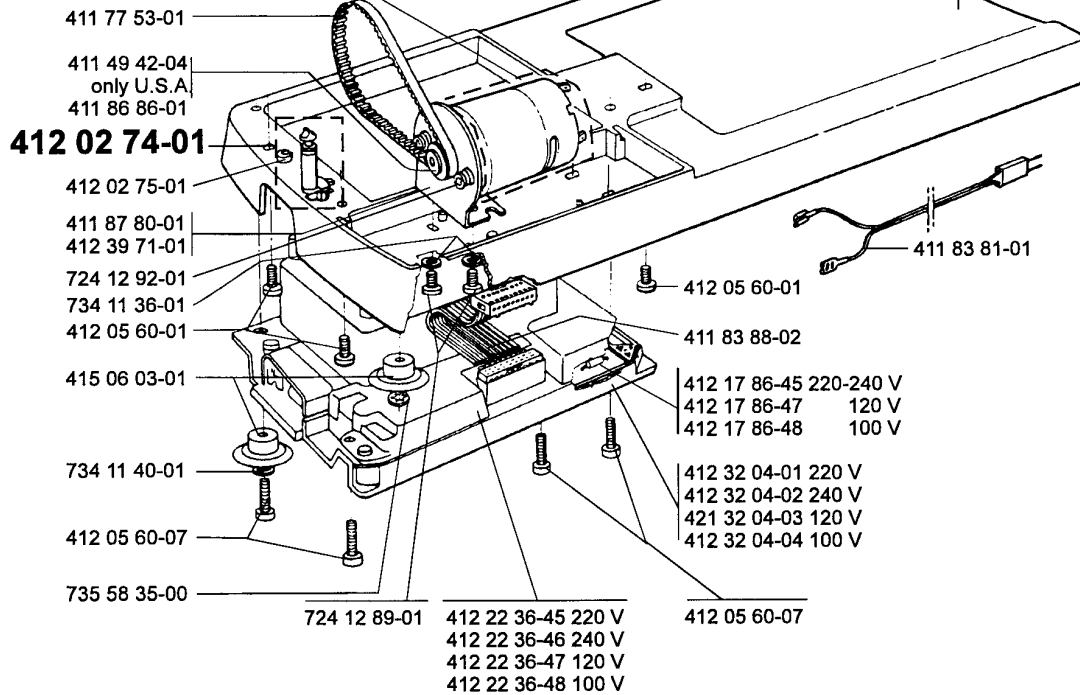

G

412 27 91-01

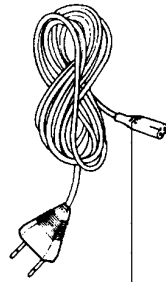
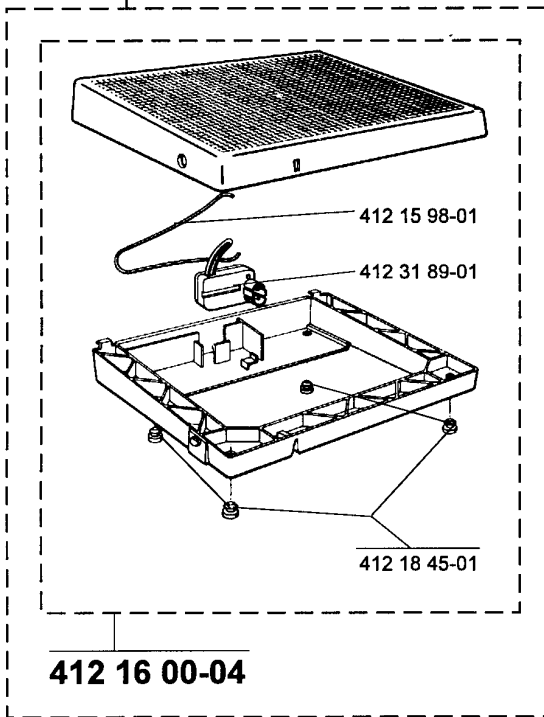

412 15 78-01 Stand.
 412 15 79-01 USA, Can
 412 15 80-02 UK
 412 15 81-01 Australia

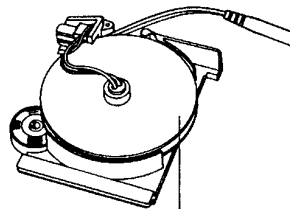

412 15 77-01

412 16 00-04

411 71 92-02

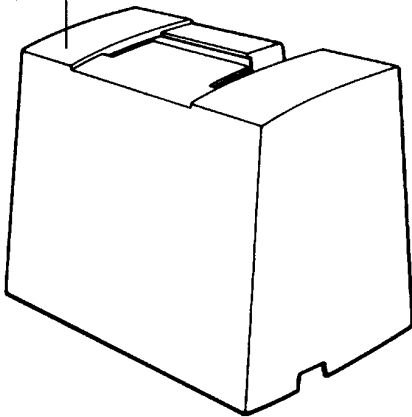

412 08 84-01

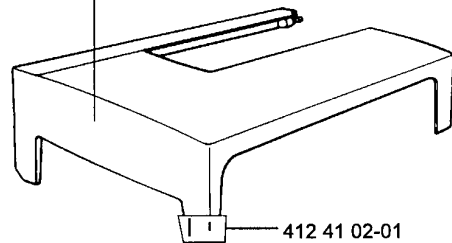

412 41 02-01

CASSETTES

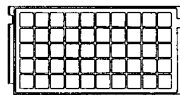

OPERATING MANUAL

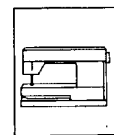

412 24 74-02

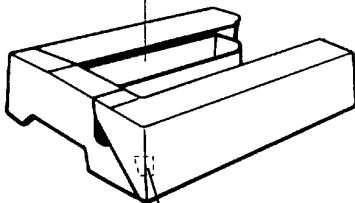

412 39 18-01



412 25 80-01
 Brush, bobbins
 e.t.c.



412 26 81-01
 Presserfoot
 e.t.c.



412 27 77-01
 Thread tension
 set



412 09 75-45
 Bobbins (10)
 set